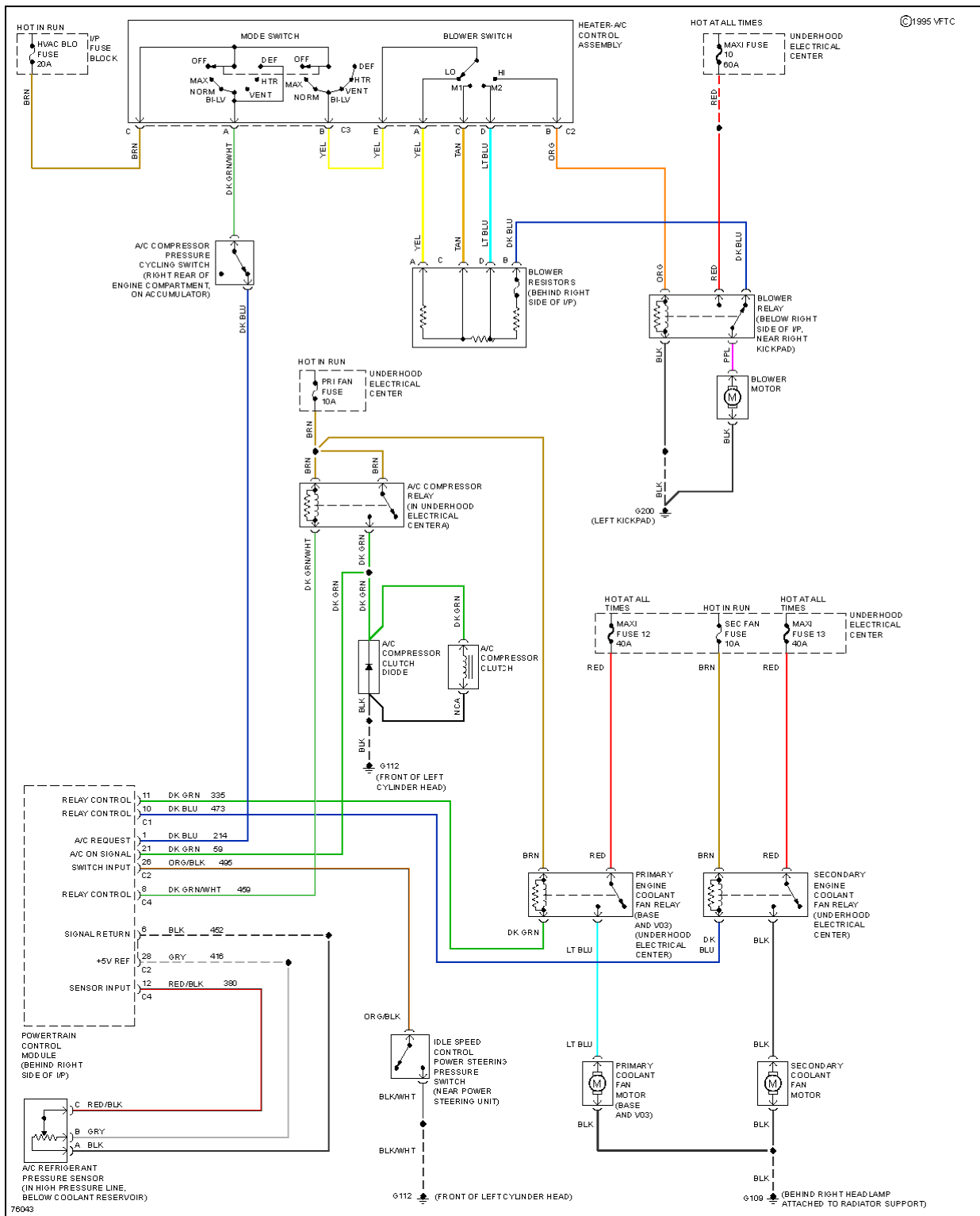
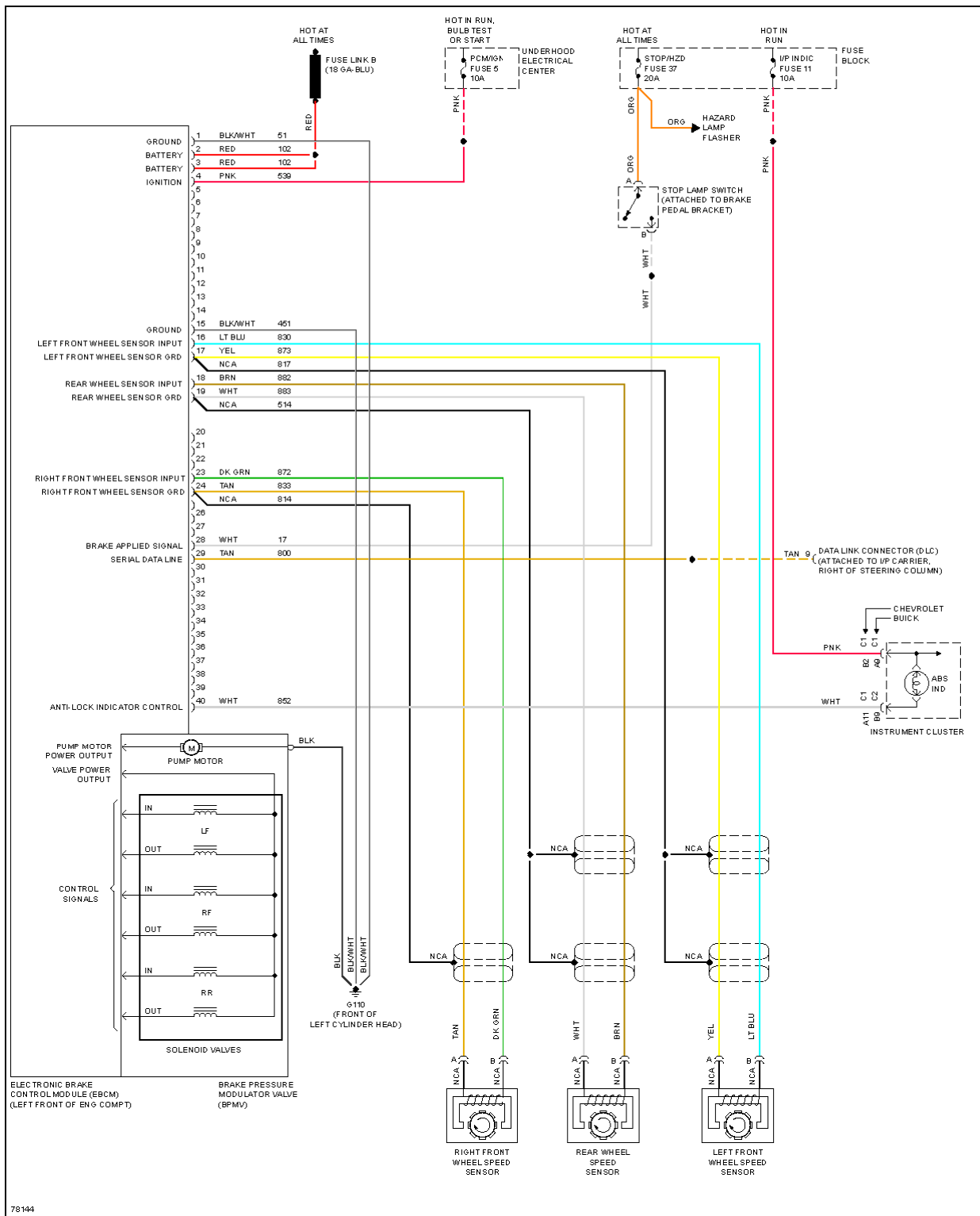


# AIR CONDITIONING



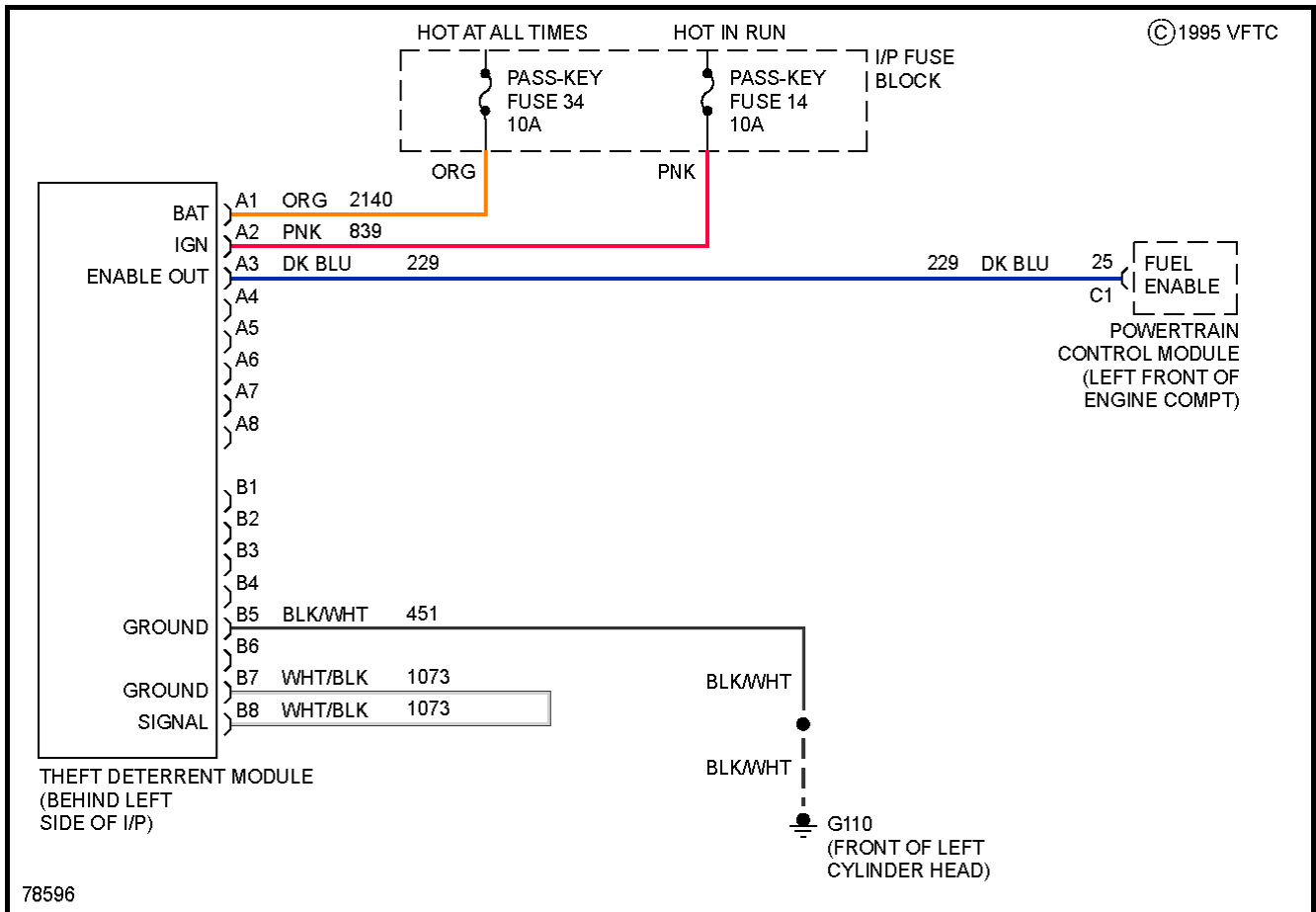
**Fig. 1: Air Conditioning Circuits**

# ANTI-LOCK BRAKES

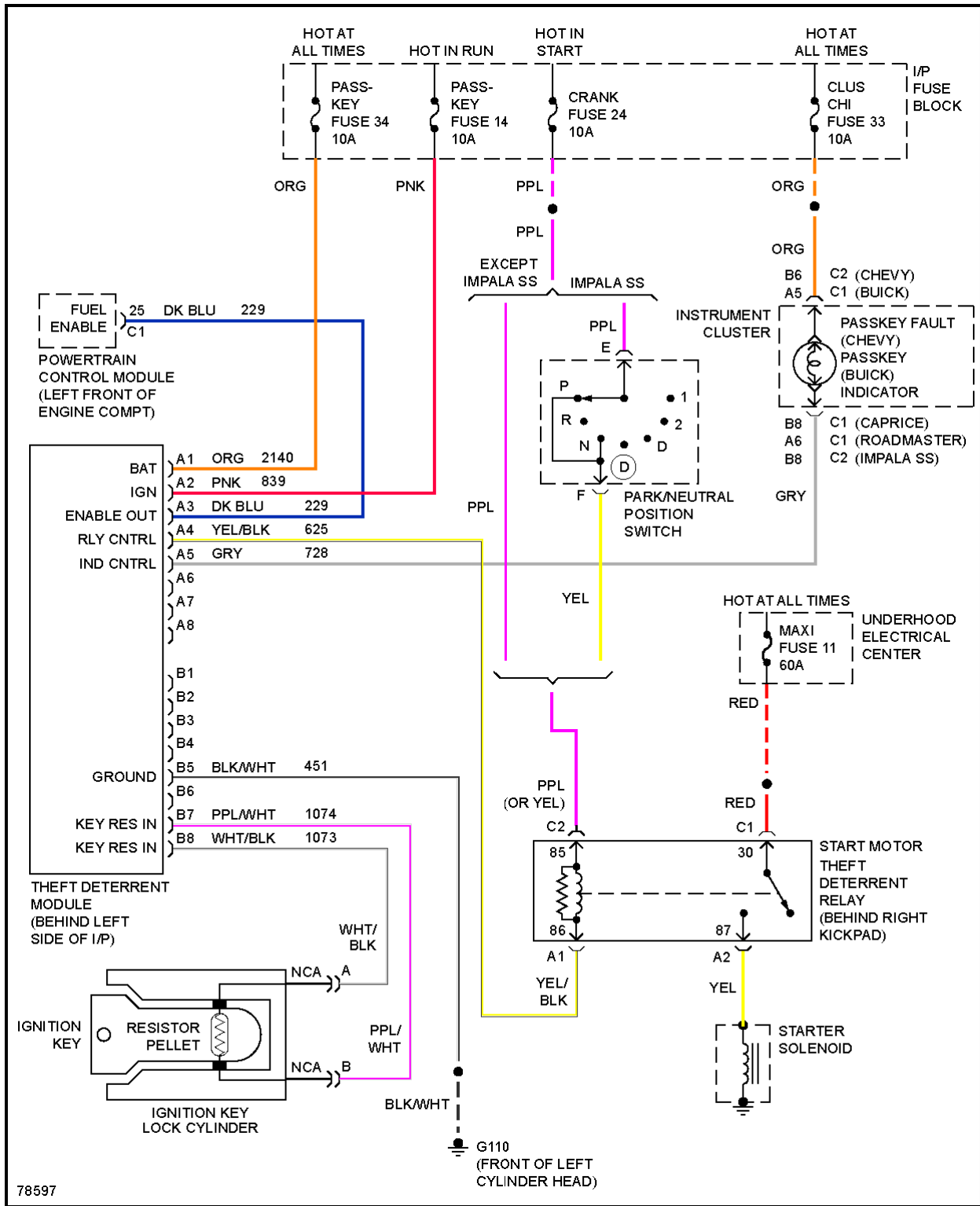


**Fig. 2: Anti-lock Brake Circuits**

# ANTI-THEFT

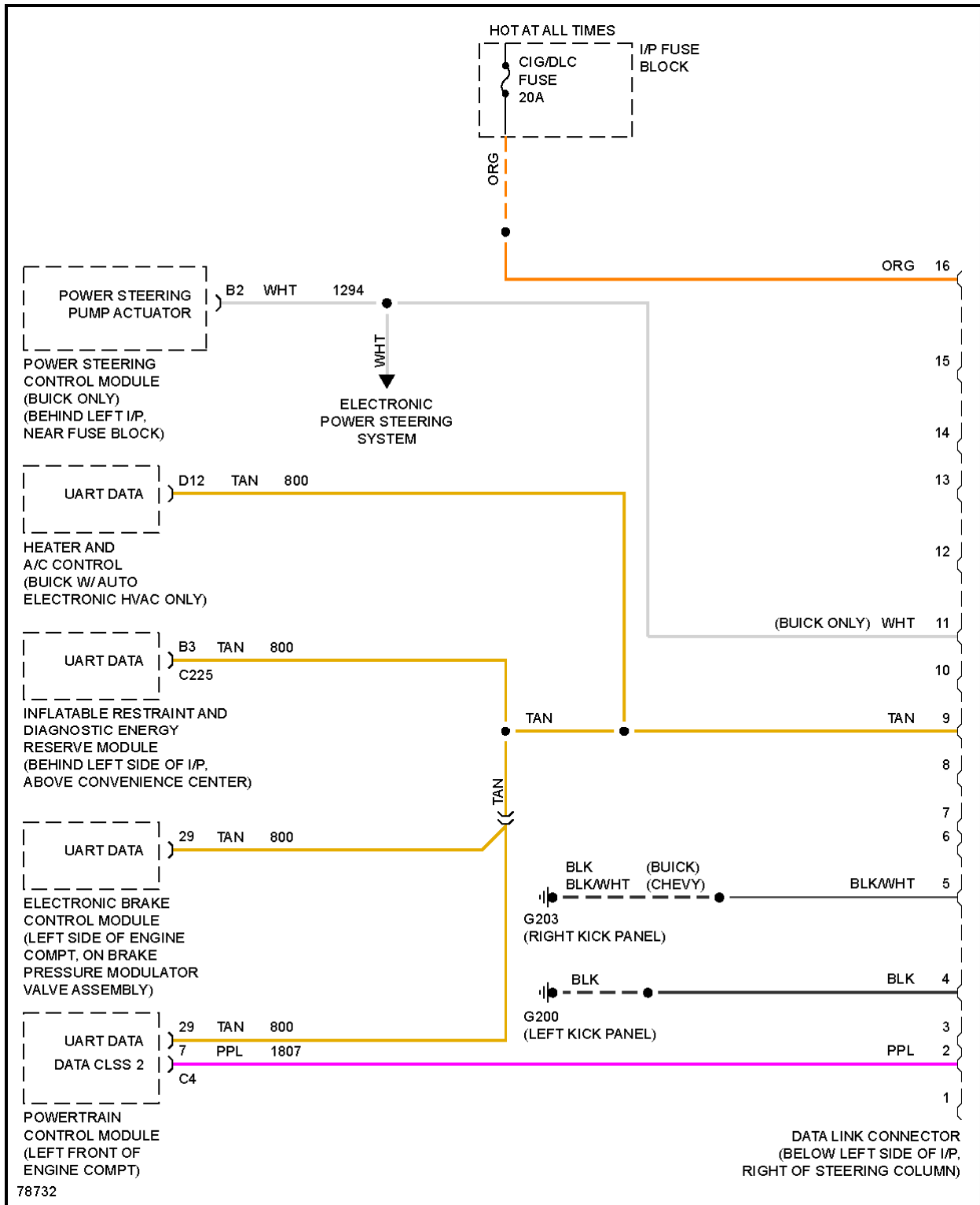


**Fig. 3: Pass-Key Circuit, W/ SEO**



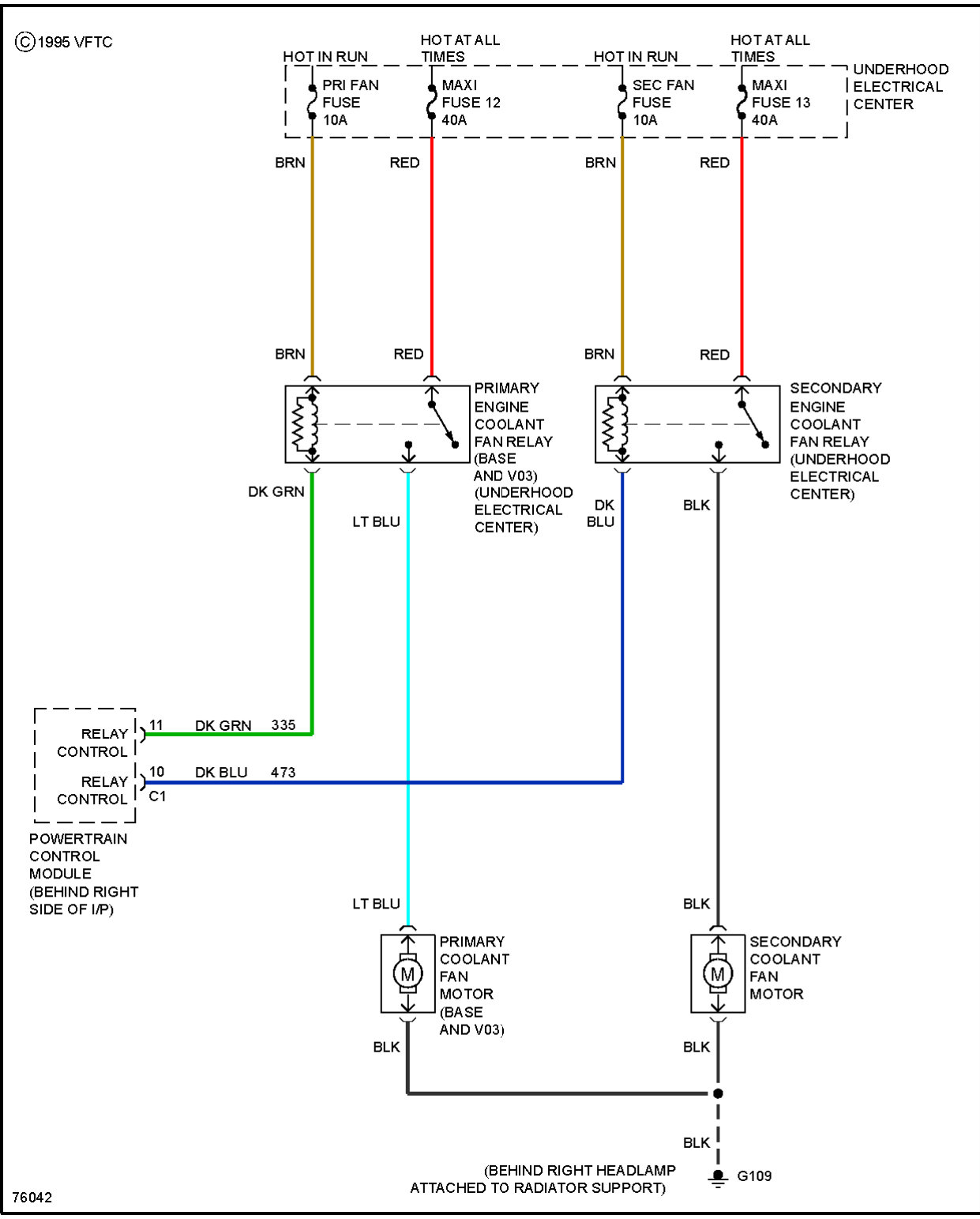
**Fig. 4: Pass-Key Circuit, W/O SEO**

**COMPUTER DATA LINES**



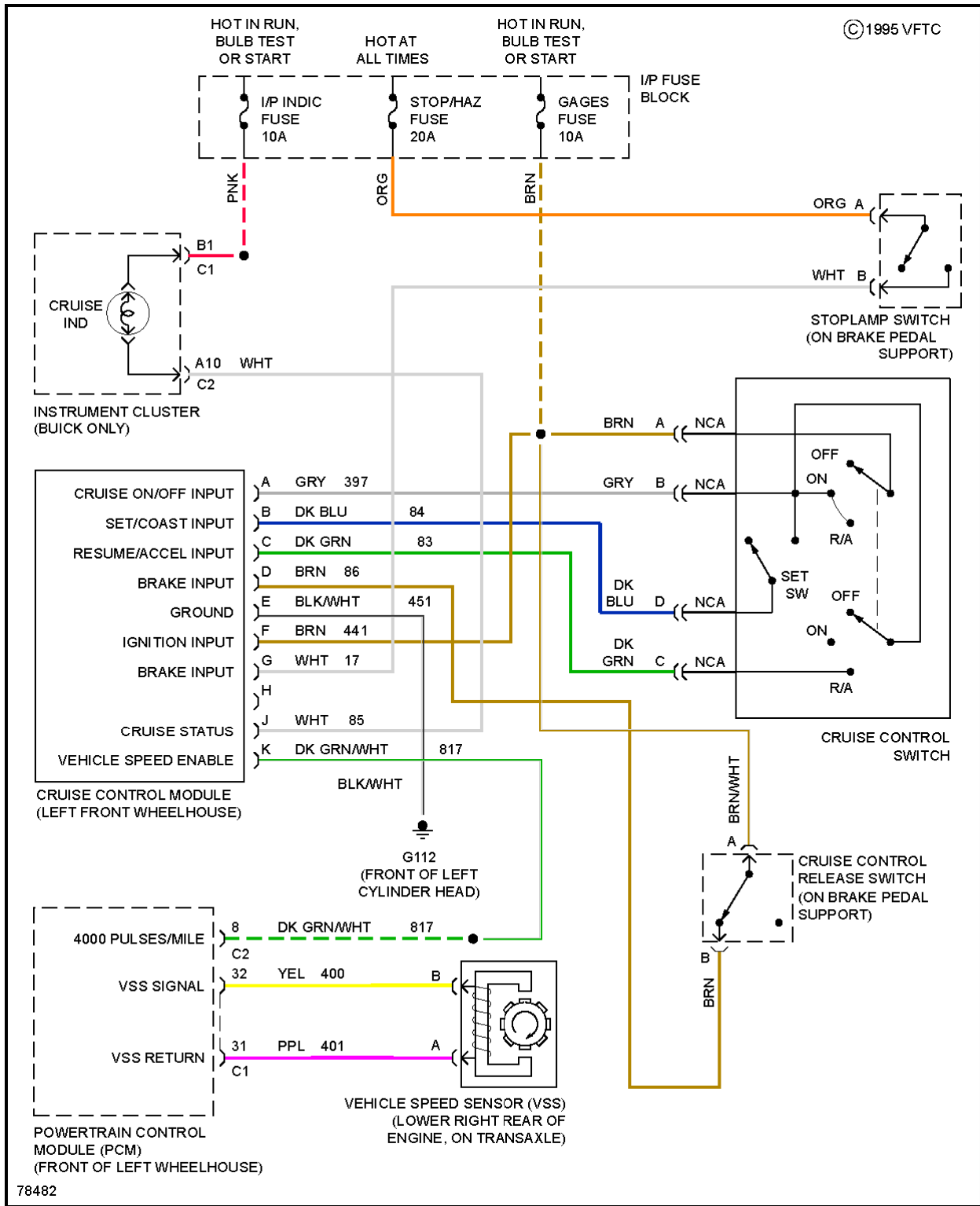
**Fig. 5: Computer Data Lines**

**COOLING FAN**



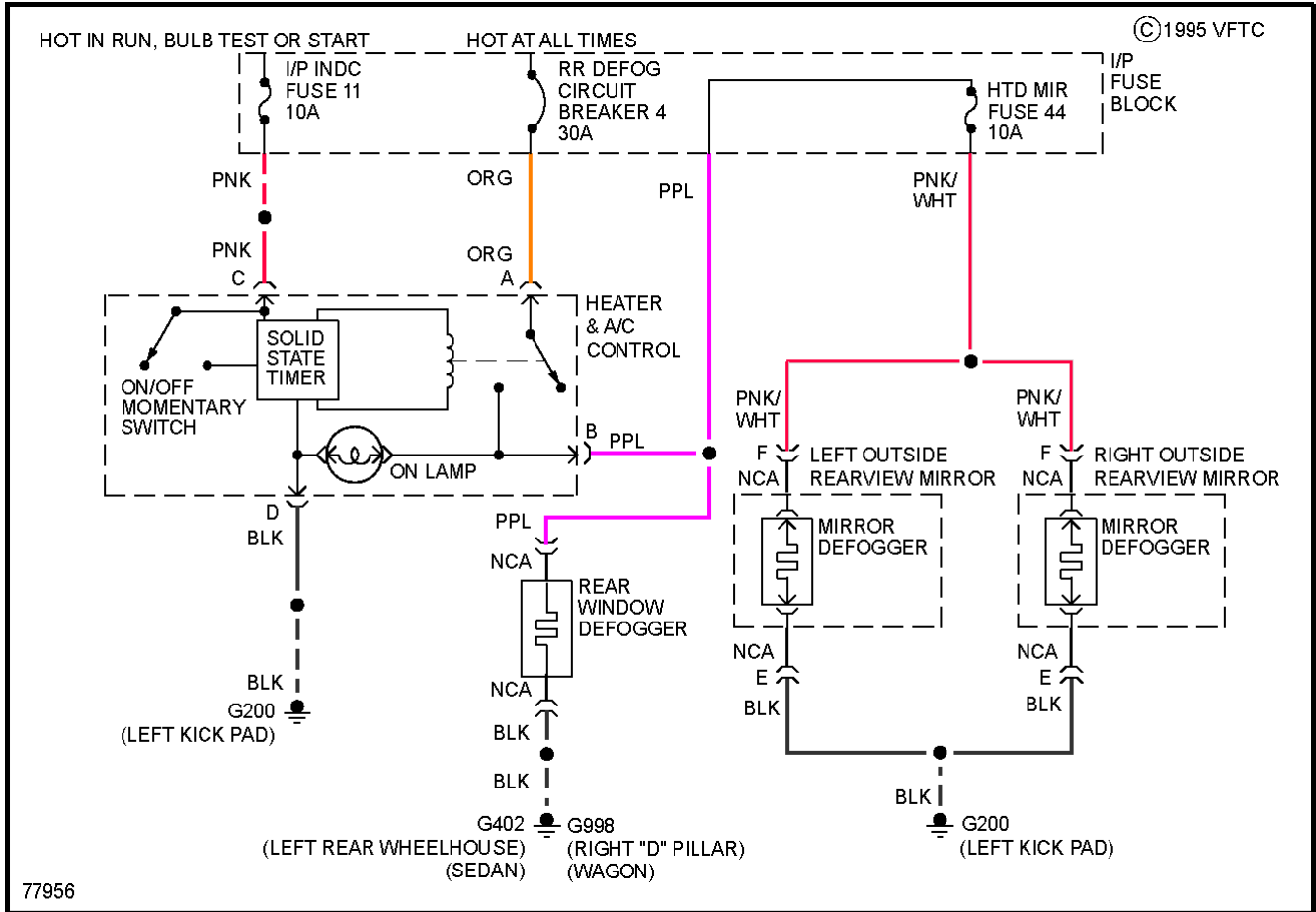
**Fig. 6: Cooling Fan Circuit**

**CRUISE CONTROL**



**Fig. 7: Cruise Control Circuit**

## DEFOGGERS



**Fig. 8: Defogger Circuit**

## ENGINE PERFORMANCE



# 5.7L

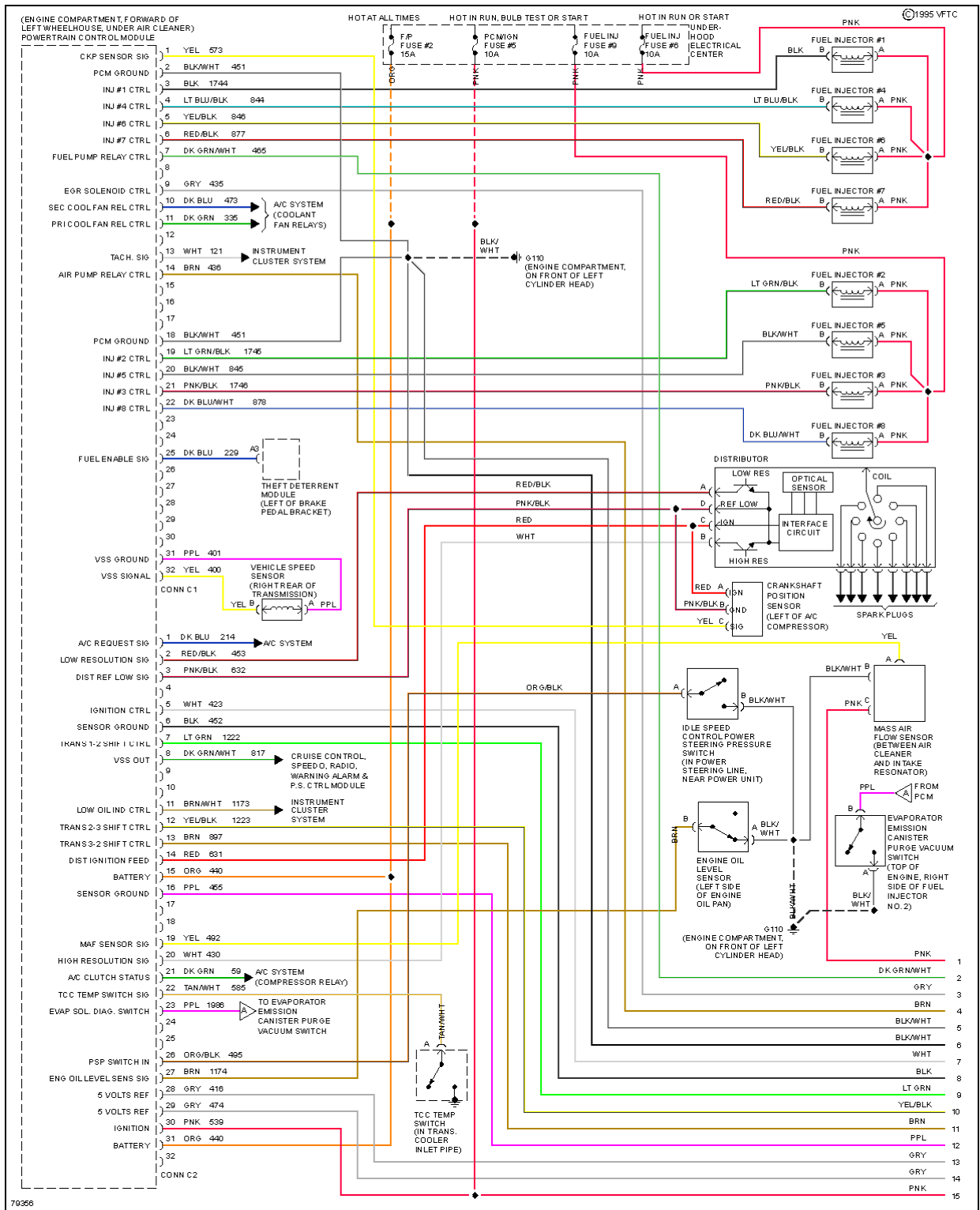
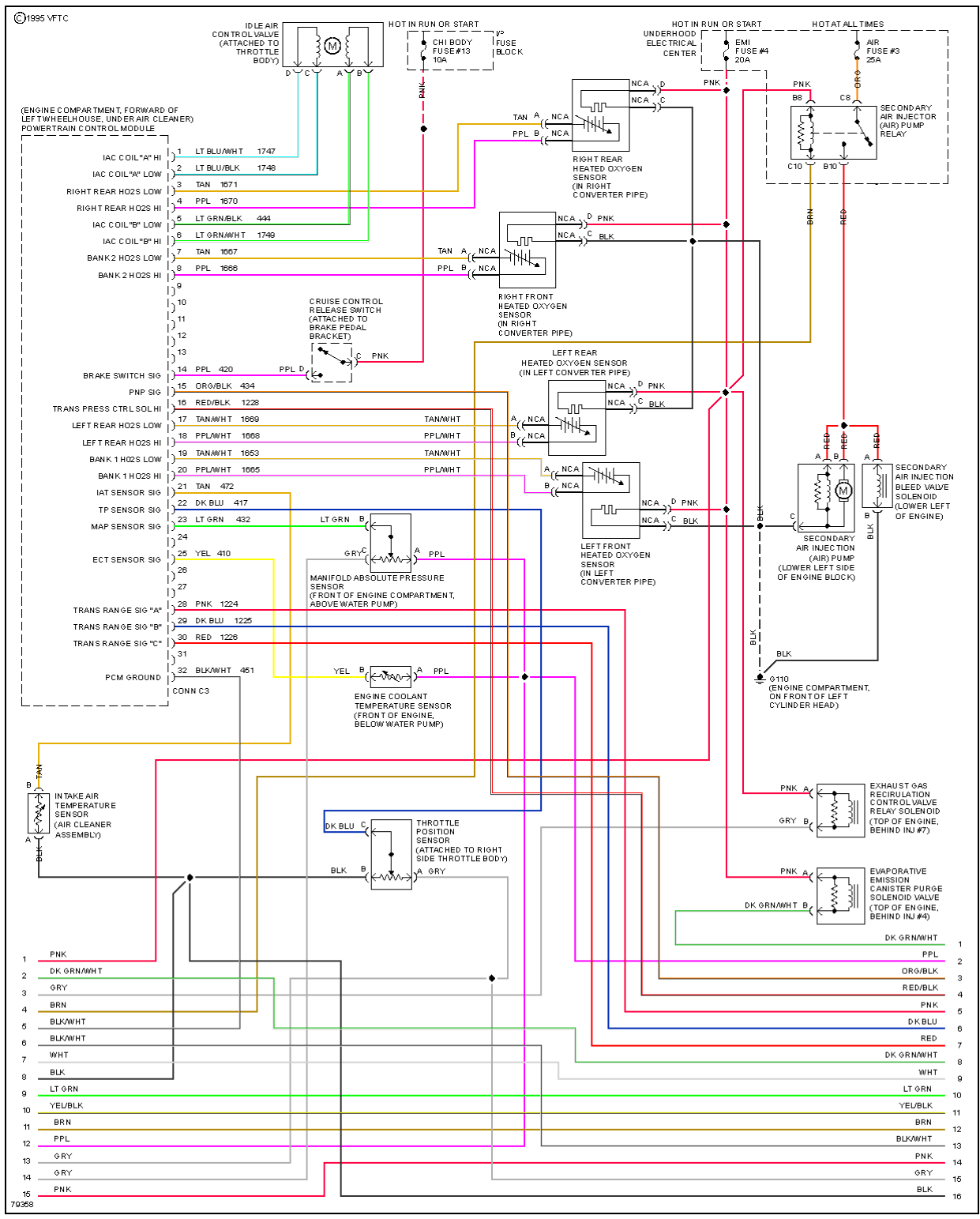


Fig. 9: 5.7L (VIN P), Engine Performance Circuits (1 of 3)



**Fig. 10: 5.7L (VIN P), Engine Performance Circuits (2 of 3)**

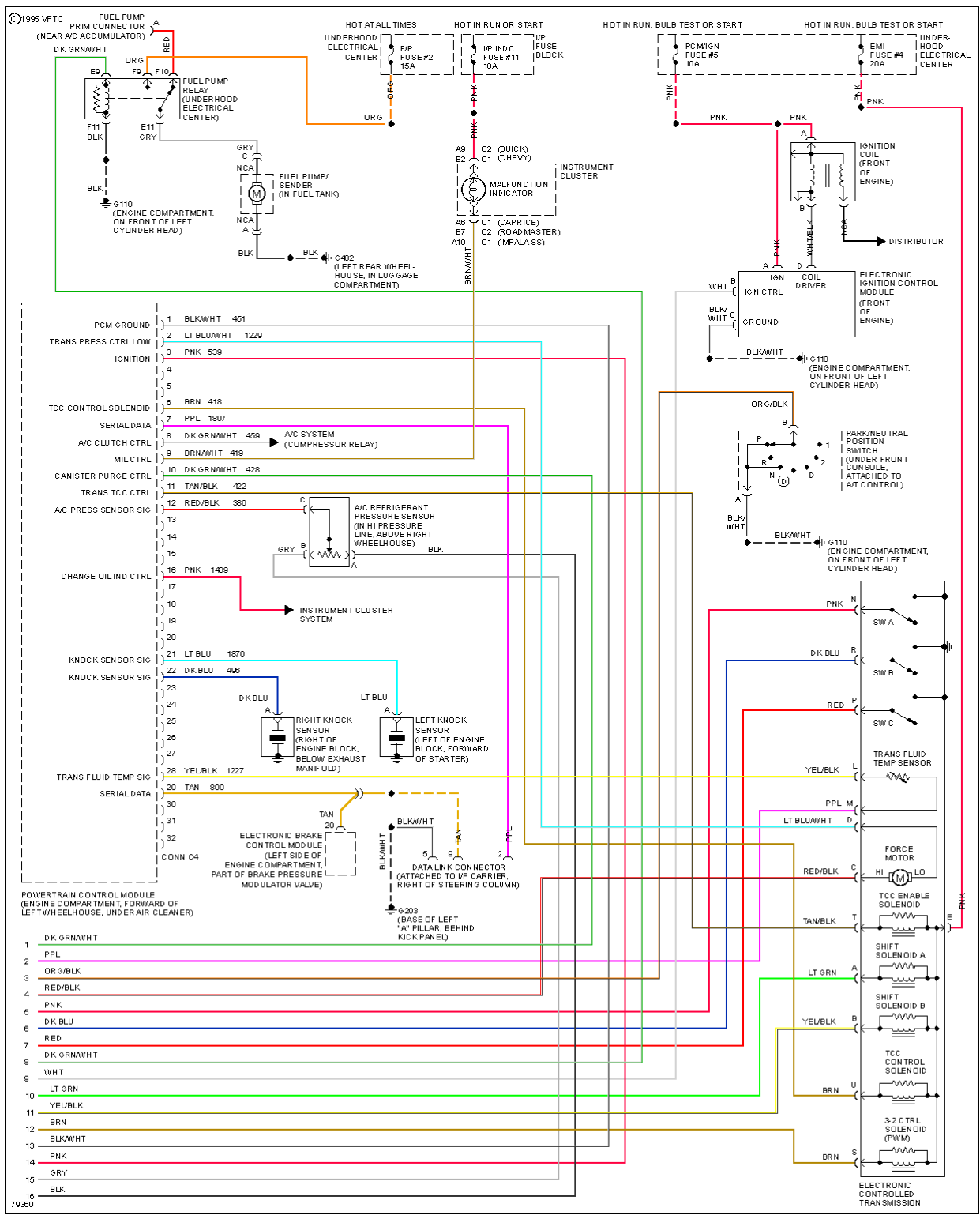
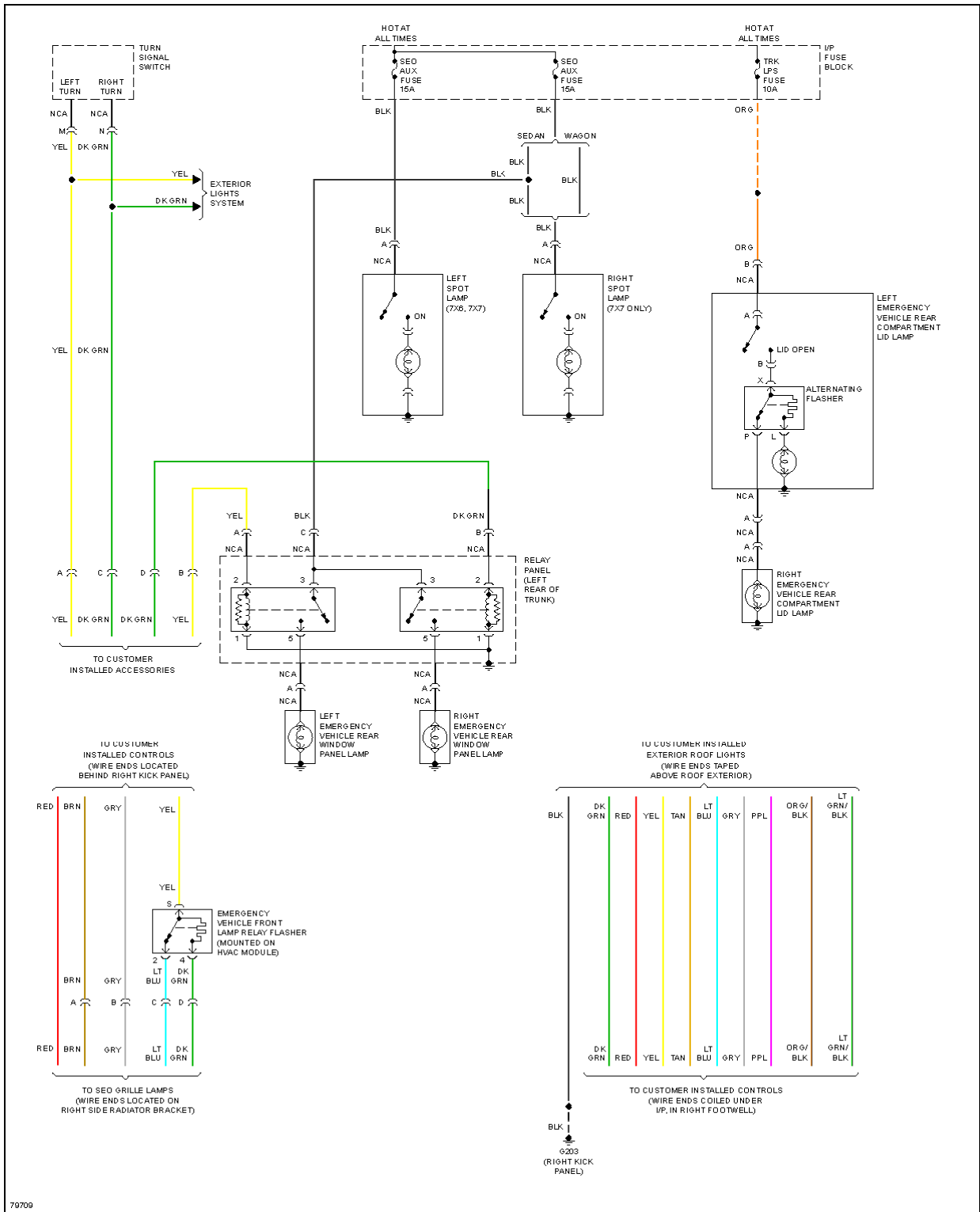
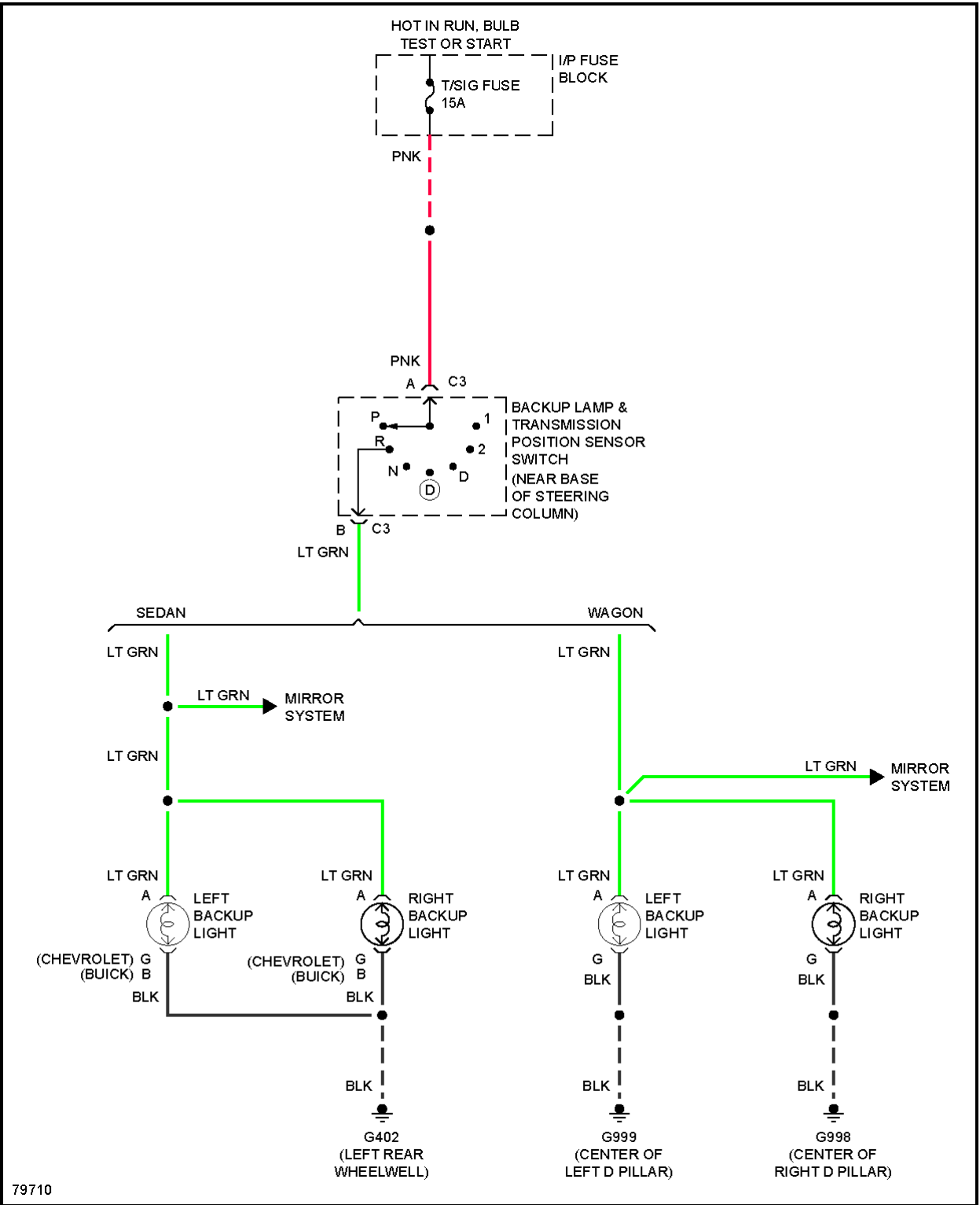


Fig. 11: 5.7L (VIN P), Engine Performance Circuits (3 of 3)

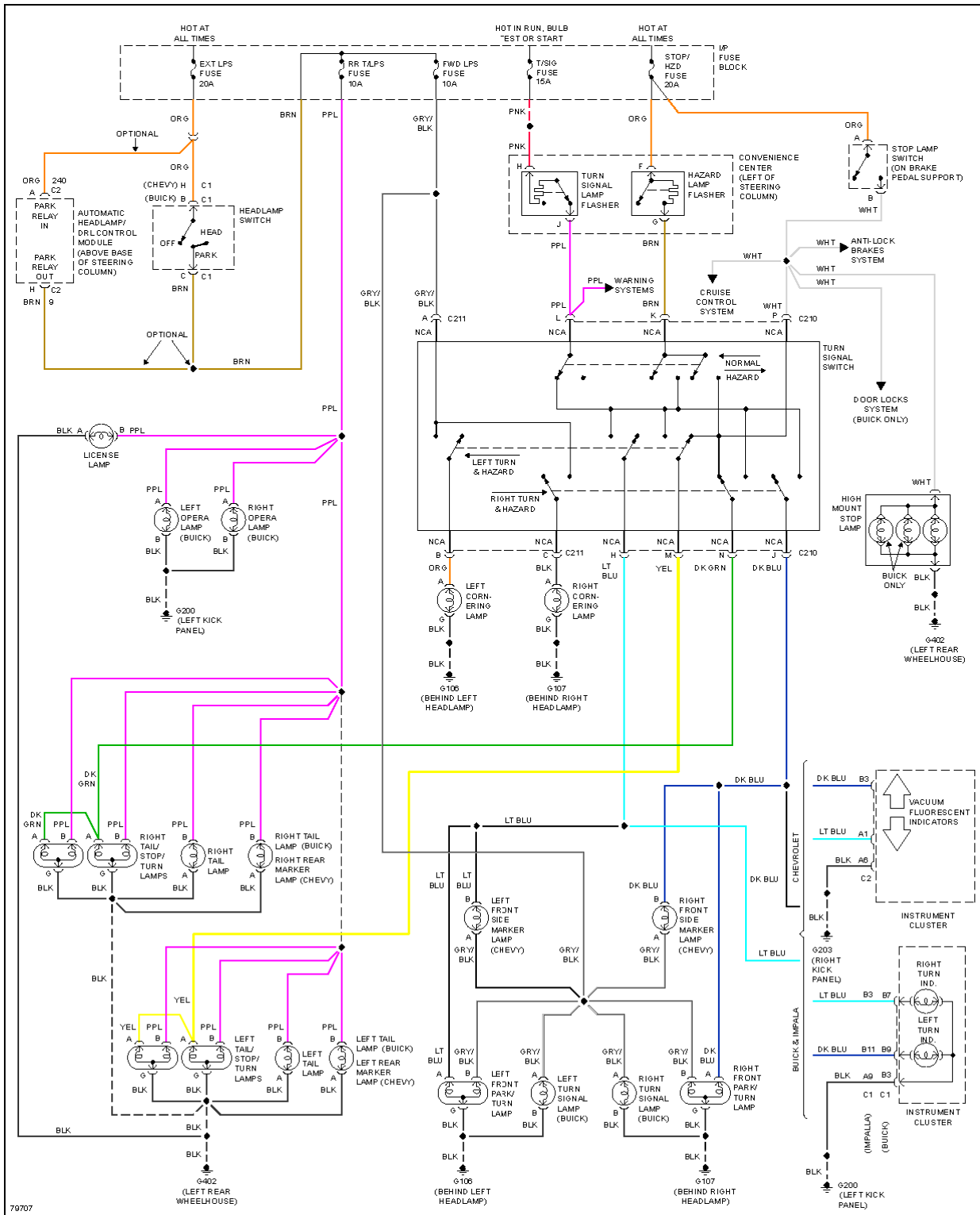
## EXTERIOR LIGHTS



**Fig. 12: Accessory Lamps Circuit**

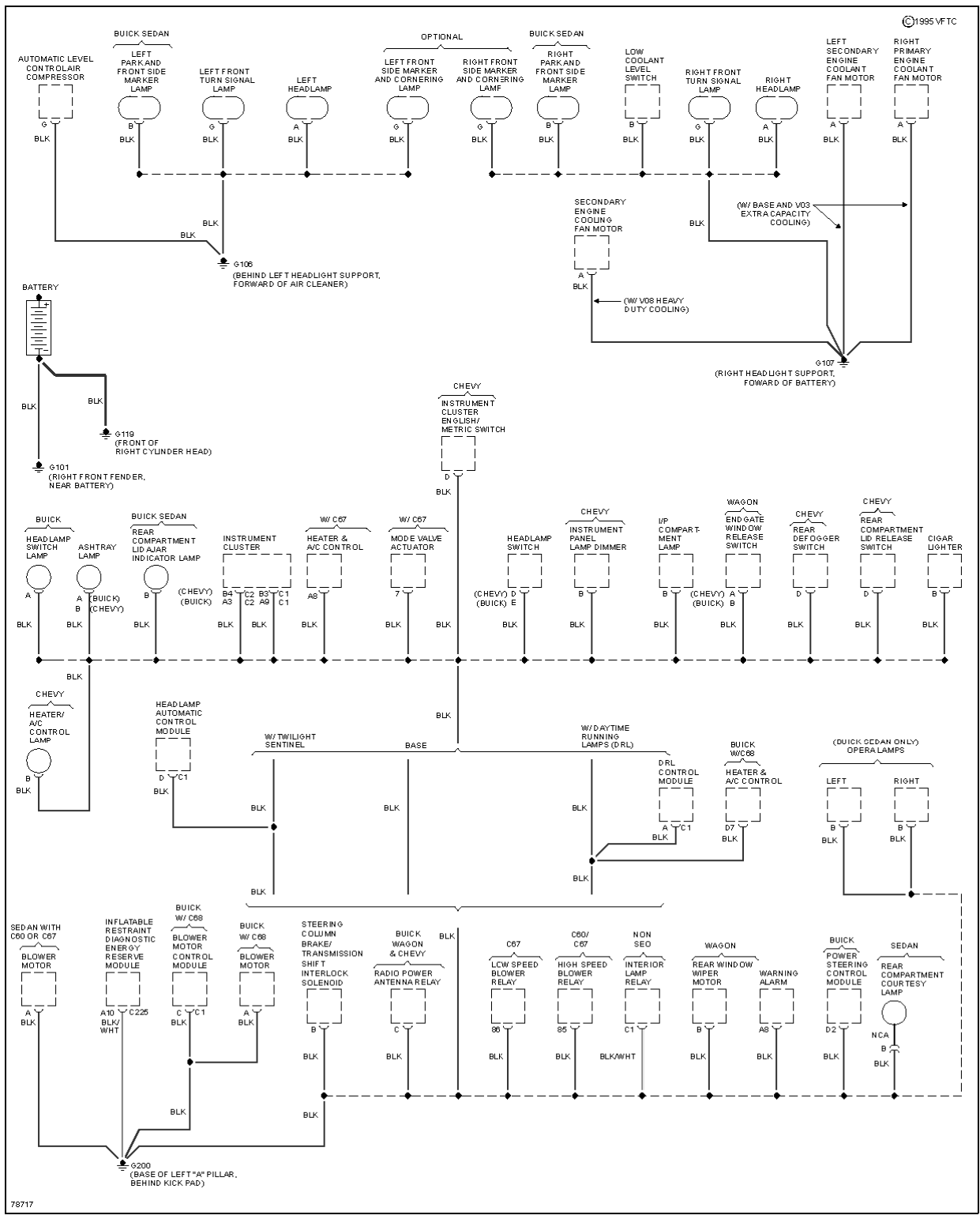


**Fig. 13: Backup Lamps Circuit**

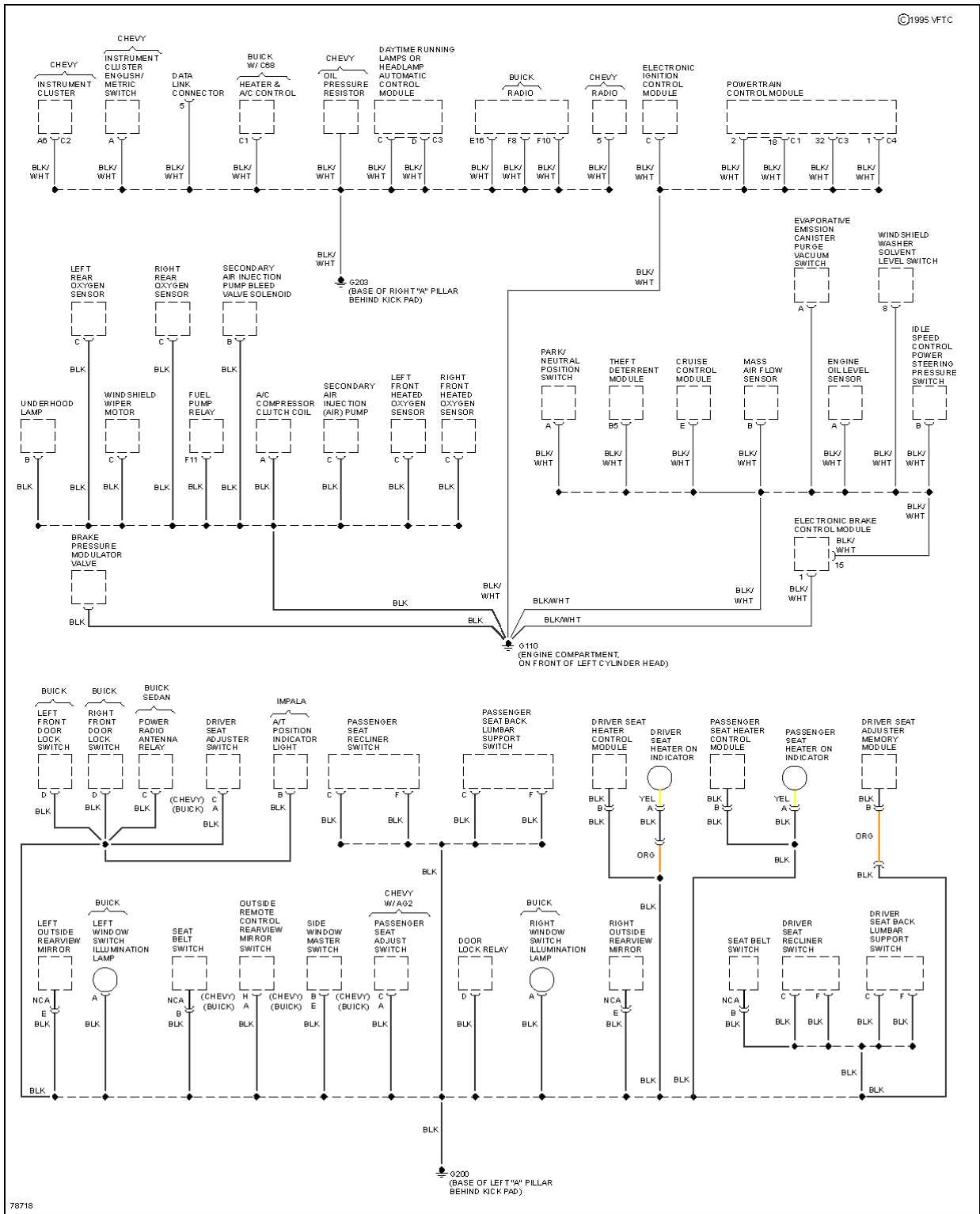


**Fig. 14: Exterior Lamps Circuit, Sedan**

## GROUND DISTRIBUTION



**Fig. 15: Ground Distribution Circuit (1 of 3)**



**Fig. 16: Ground Distribution Circuit (2 of 3)**



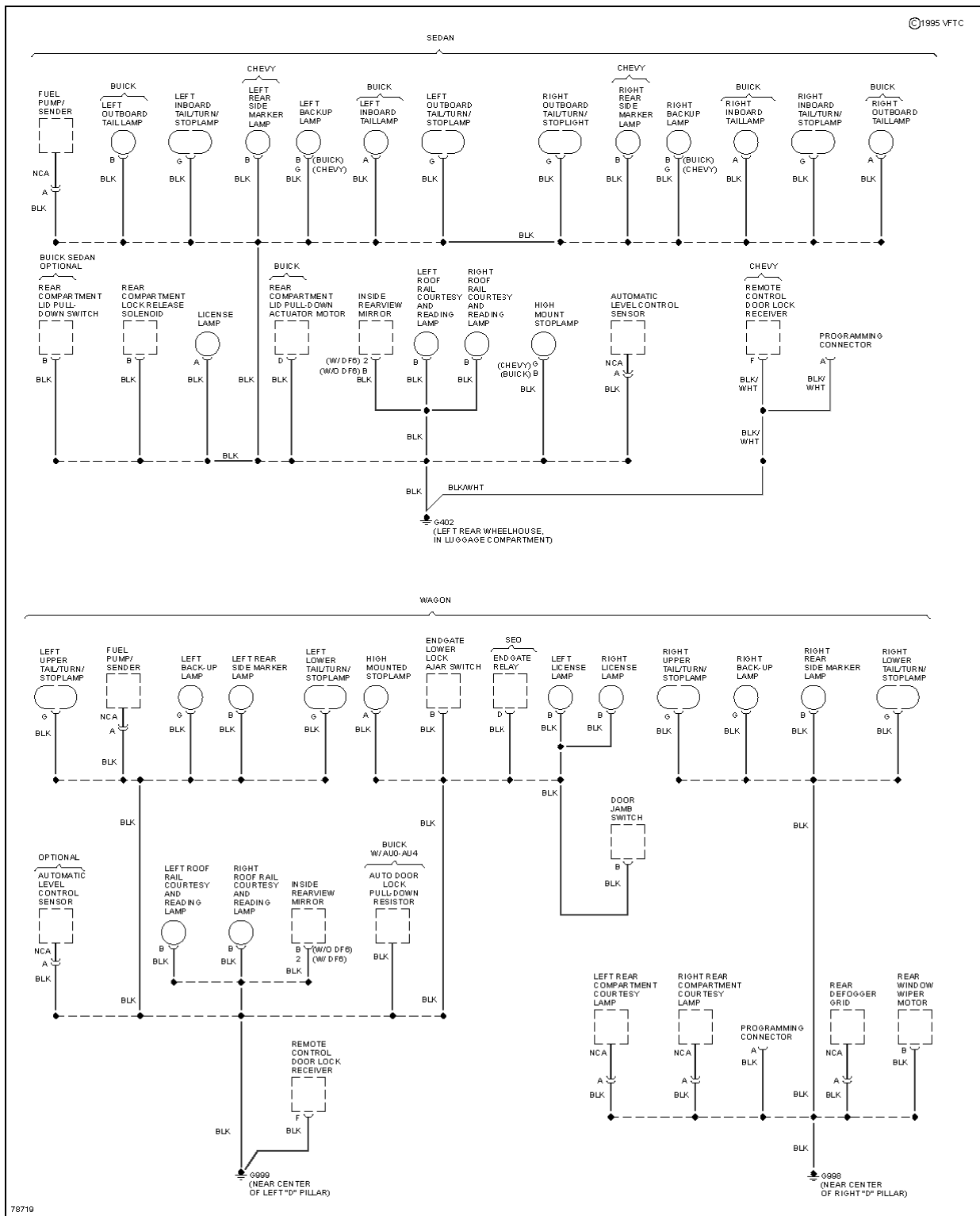
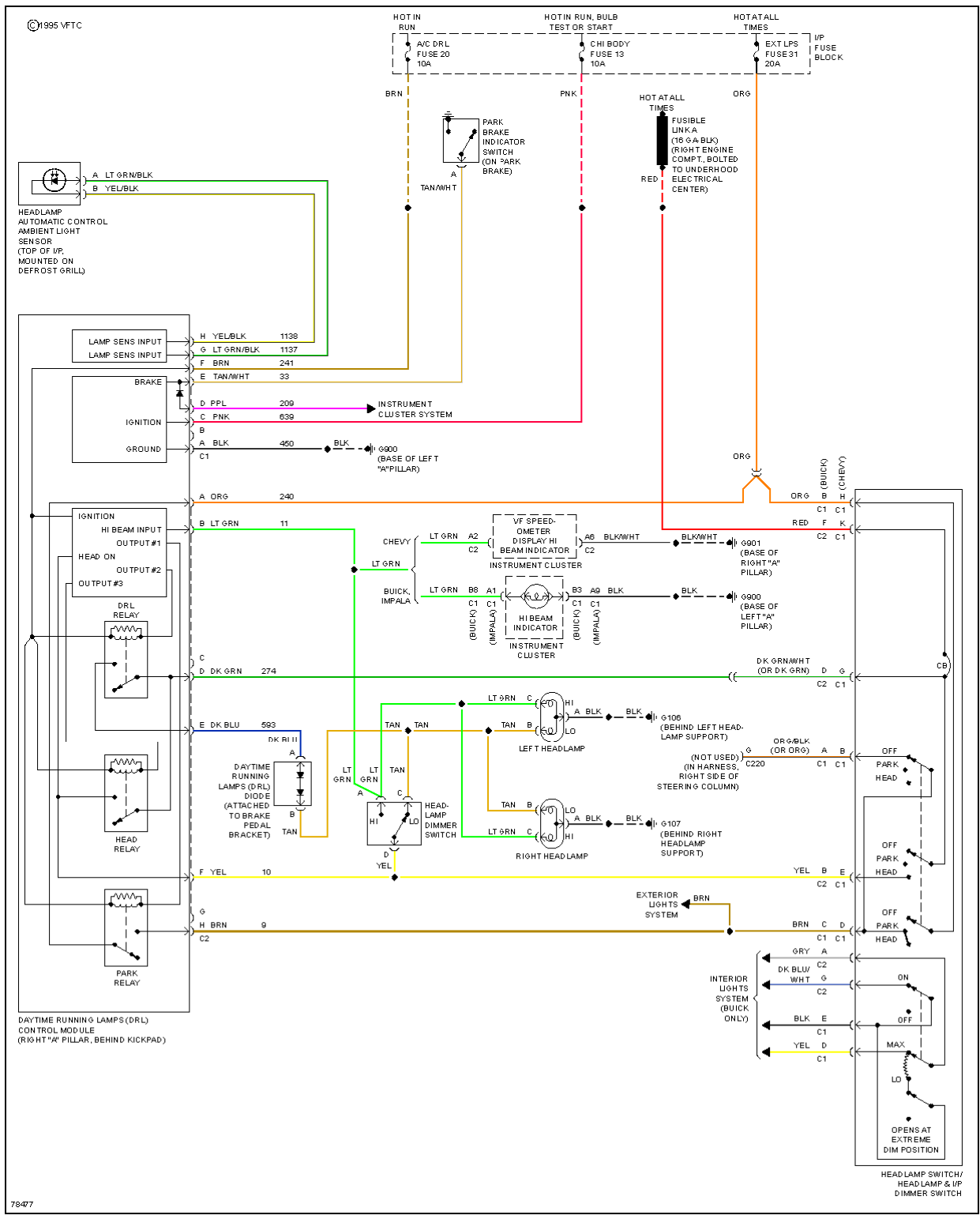
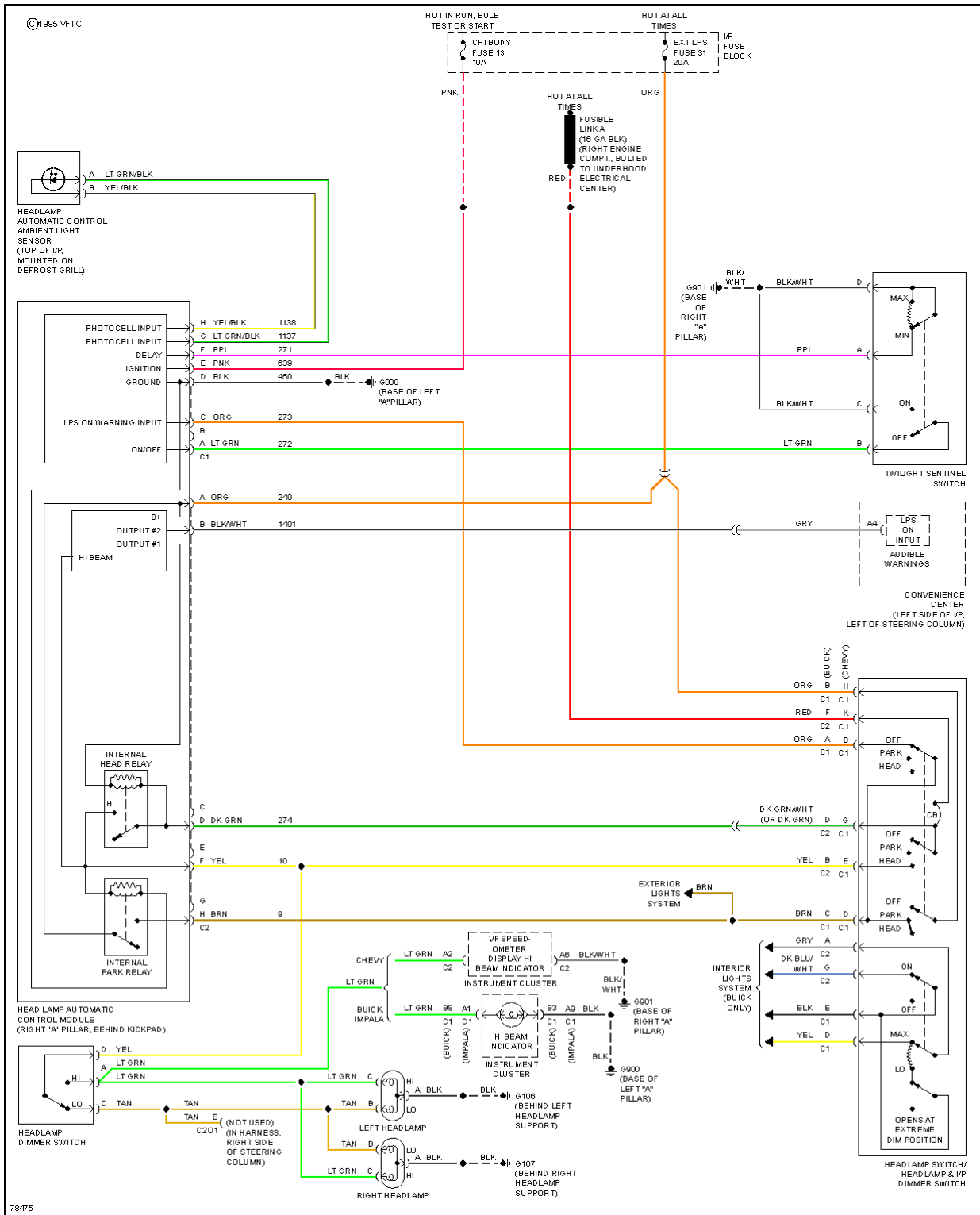


Fig. 17: Ground Distribution Circuit (3 of 3)

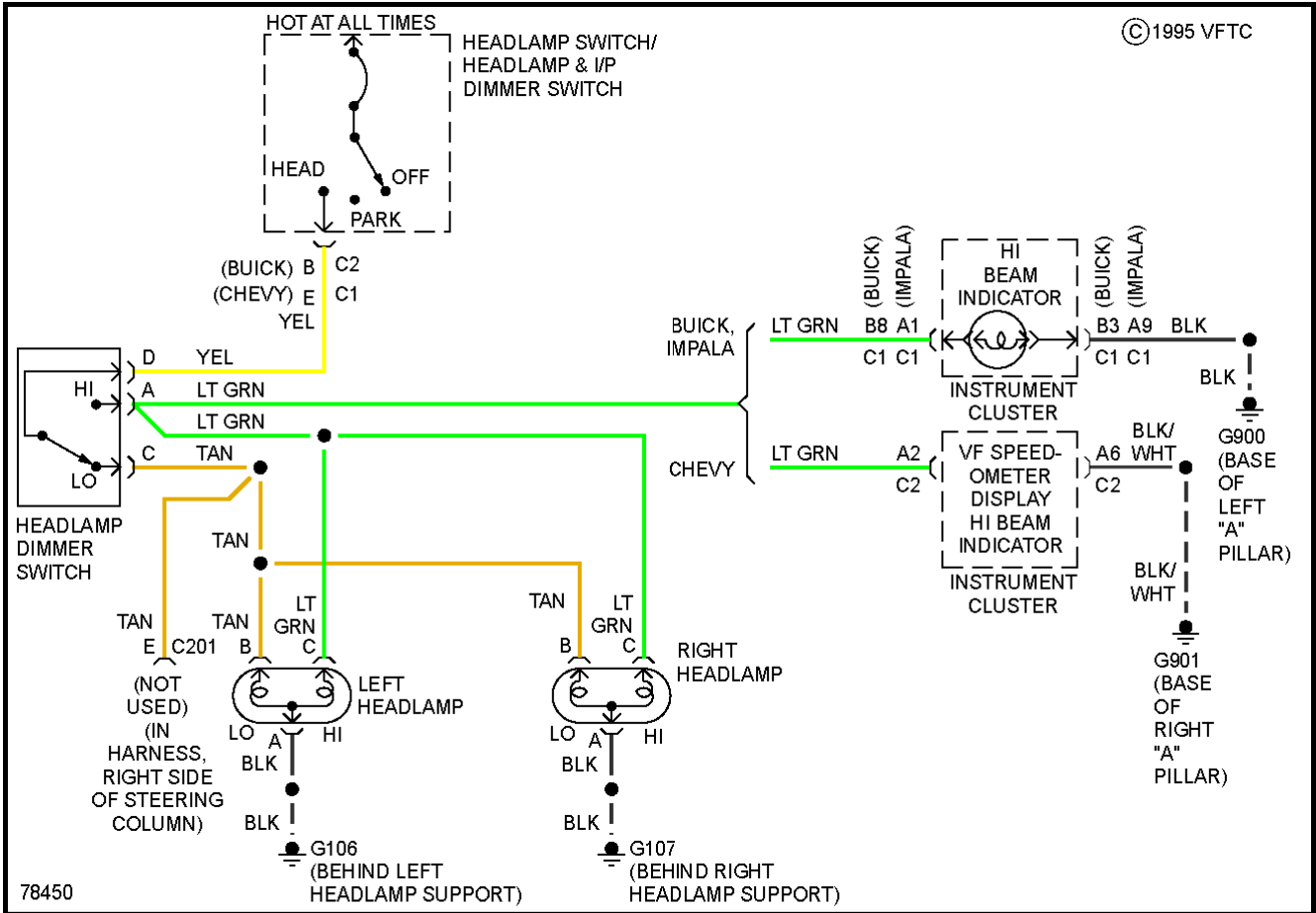
# HEADLIGHTS



**Fig. 18: Headlight Circuit, W/ DRL**

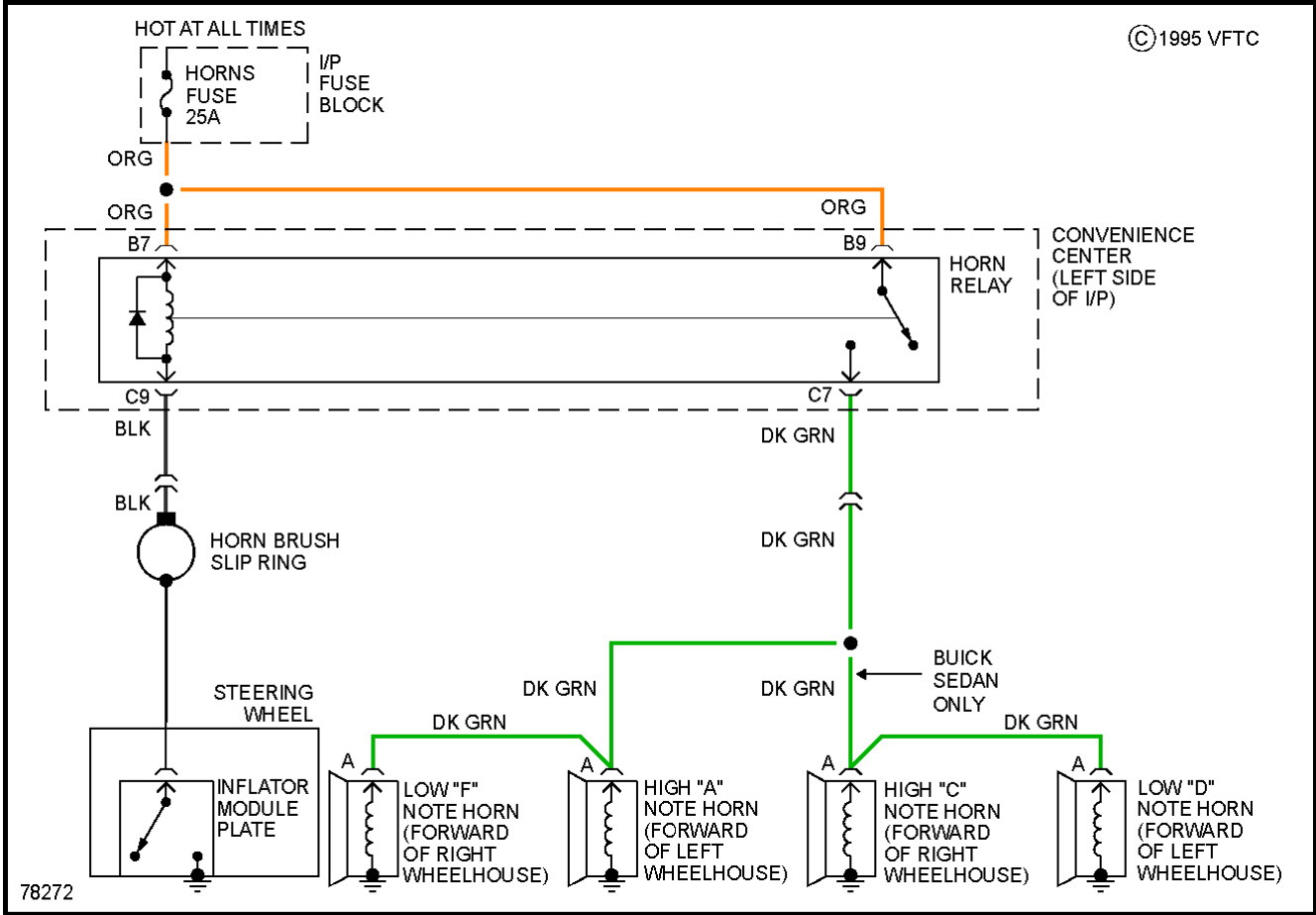


**Fig. 19: Headlight Circuit, W/O DRL, W/ Twilight Sentinel**



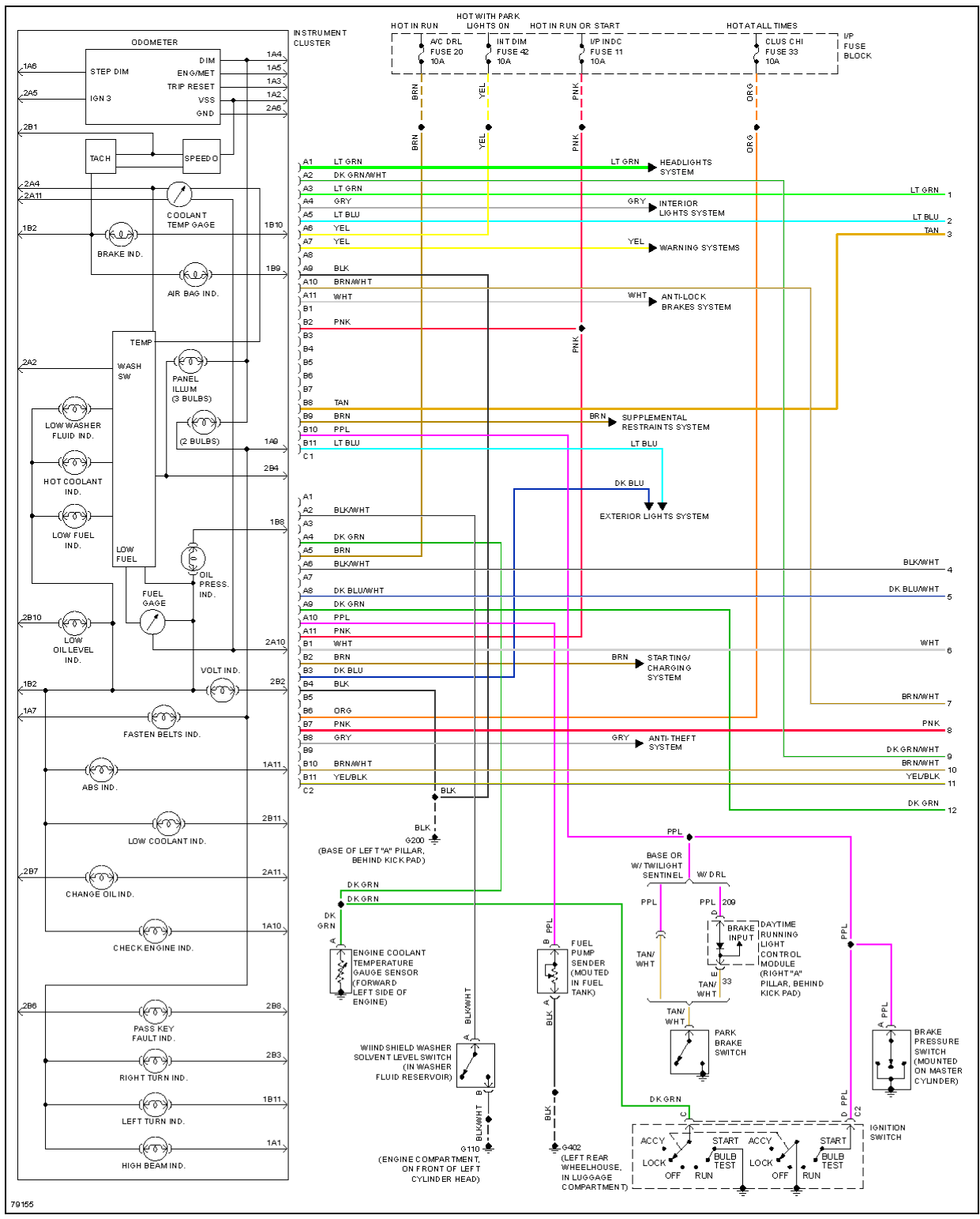
**Fig. 20: Headlight Circuit, W/O DRL, W/O Twilight Sentinel**

**HORN**

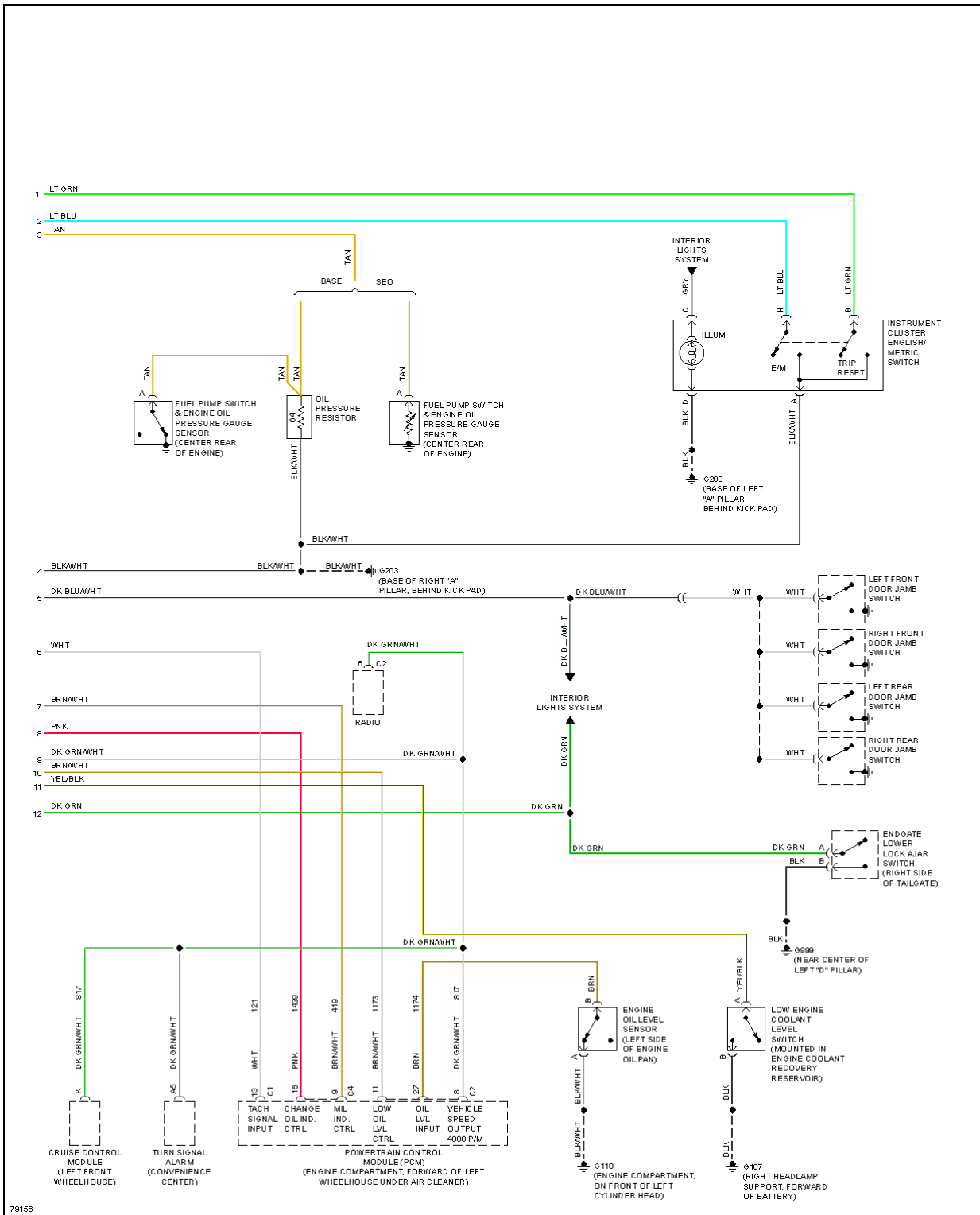


**Fig. 21: Horn Circuit**

**INSTRUMENT CLUSTER**

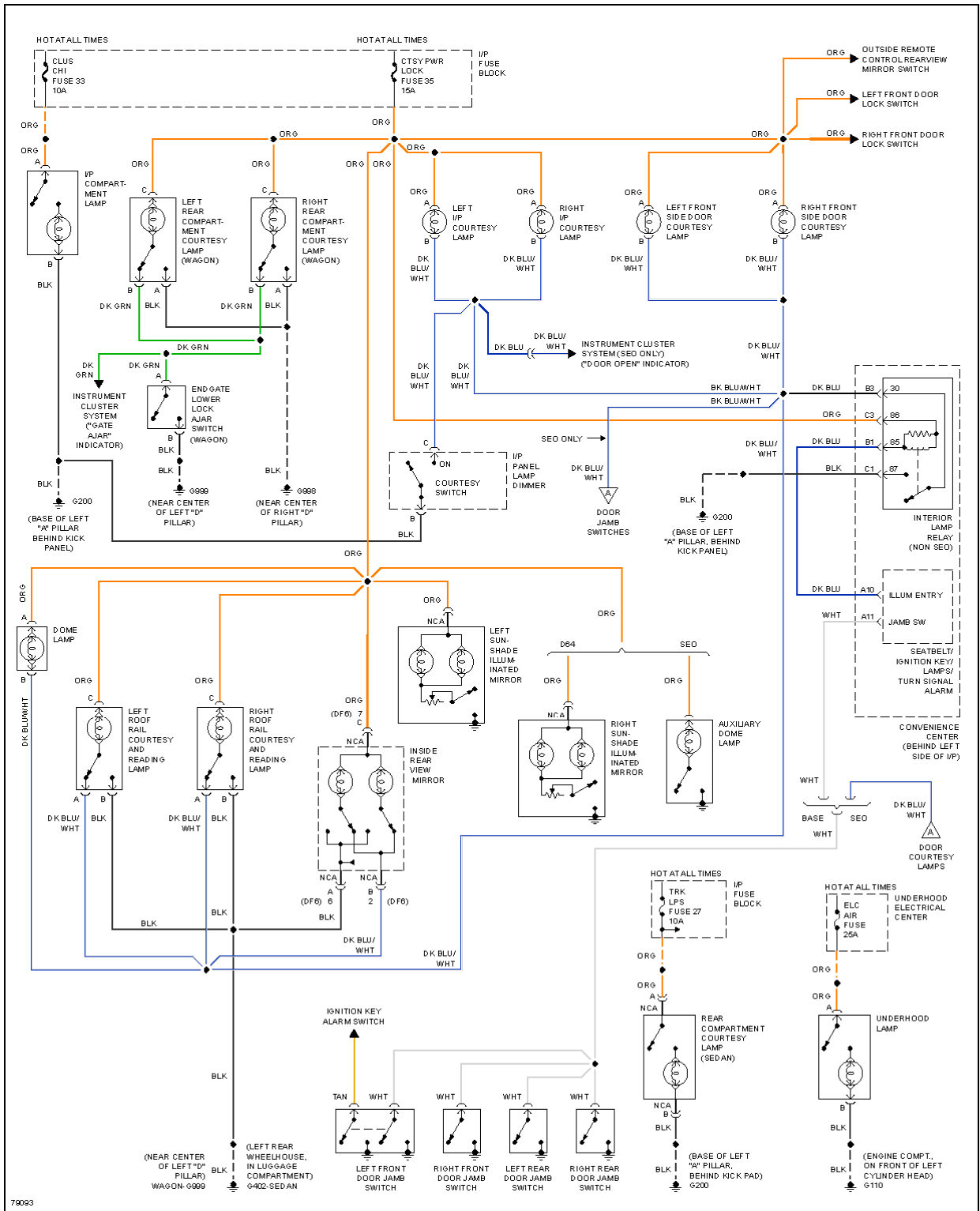


**Fig. 22: Instrument Cluster Circuit (1 of 2)**



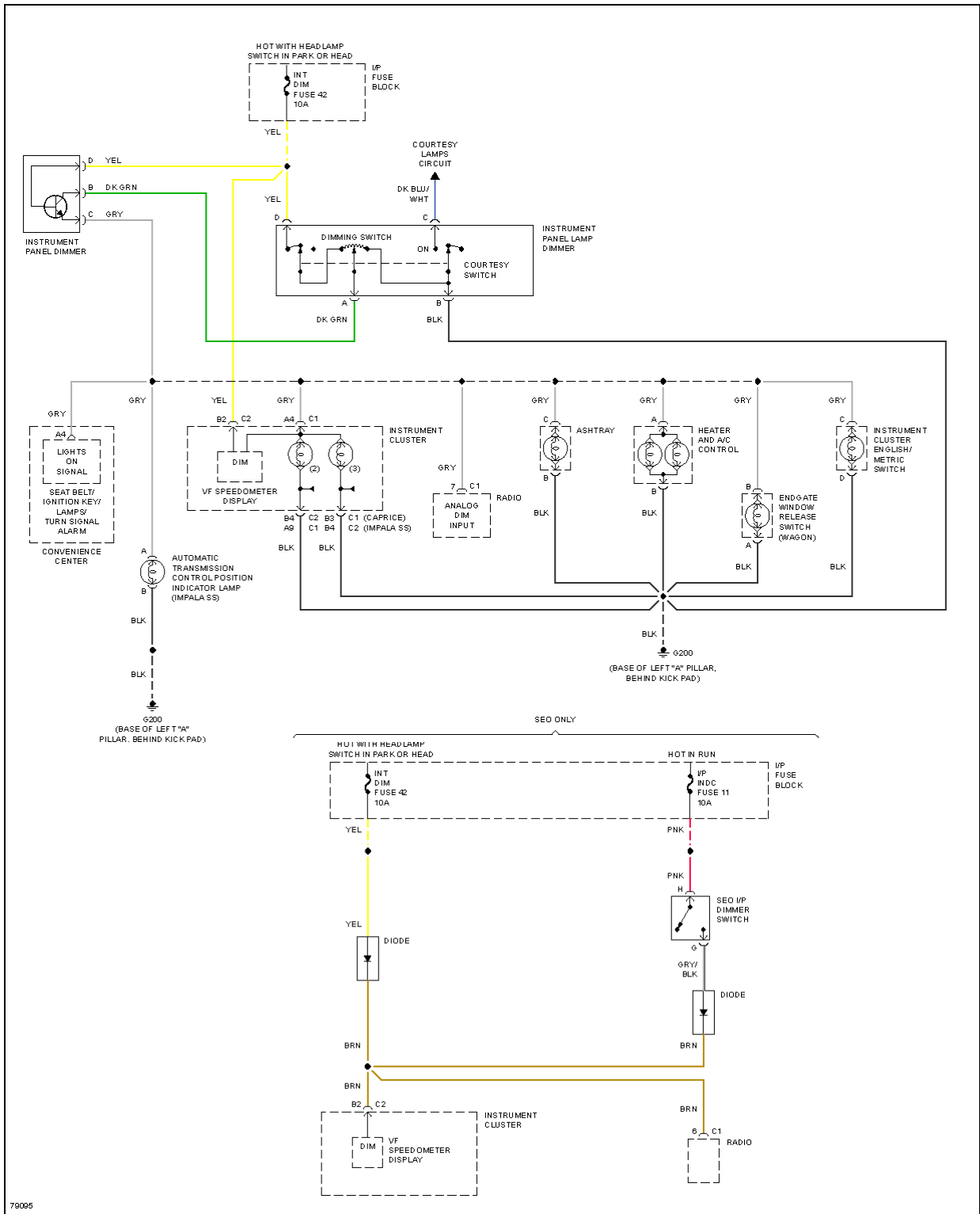
**Fig. 23: Instrument Cluster Circuit (2 of 2)**

## INTERIOR LIGHTS



**Fig. 24: Courtesy Lamps Circuit**

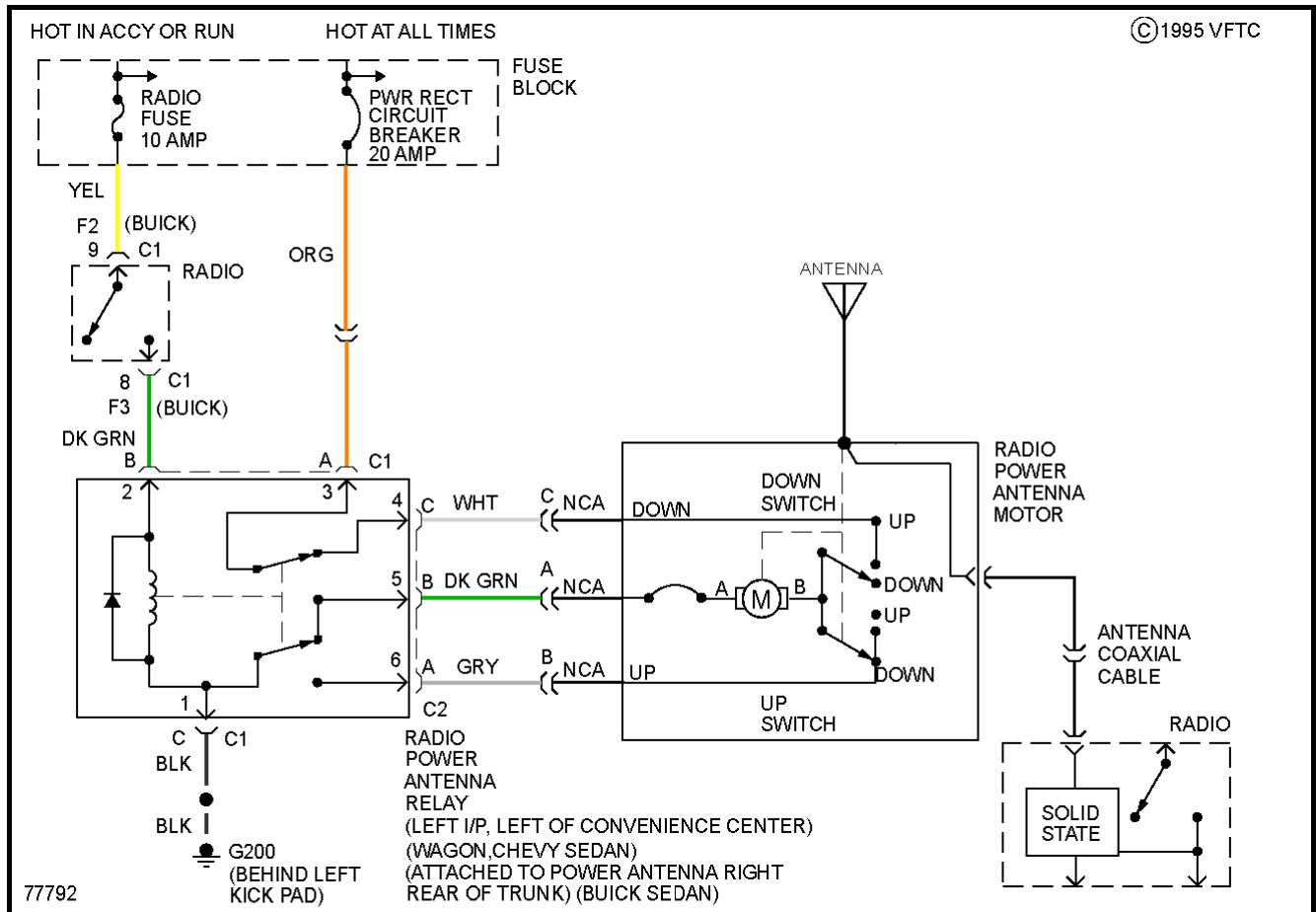




79005

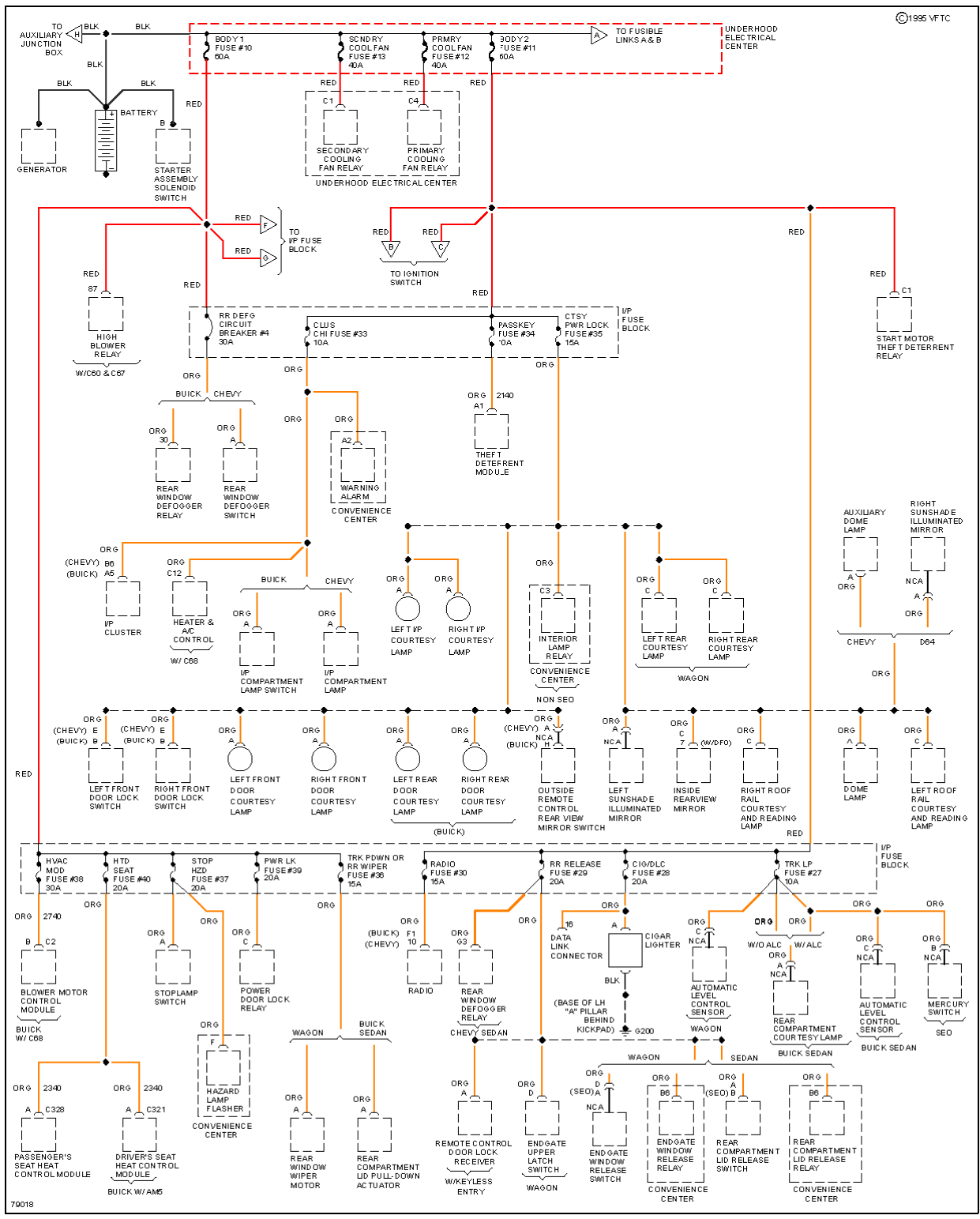
**Fig. 25: Instrument Illumination Circuit**

**POWER ANTENNA**

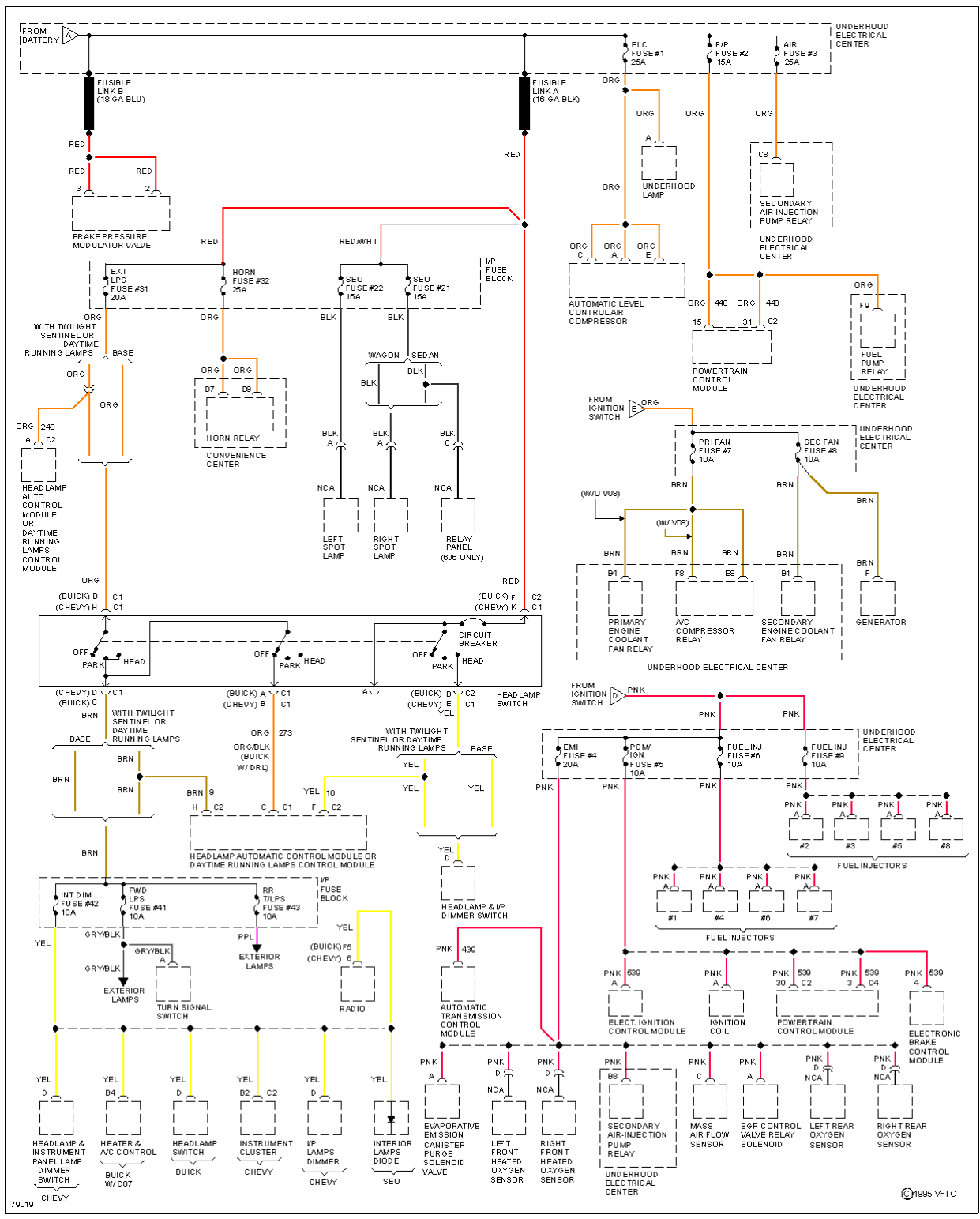


**Fig. 26: Power Antenna Circuit**

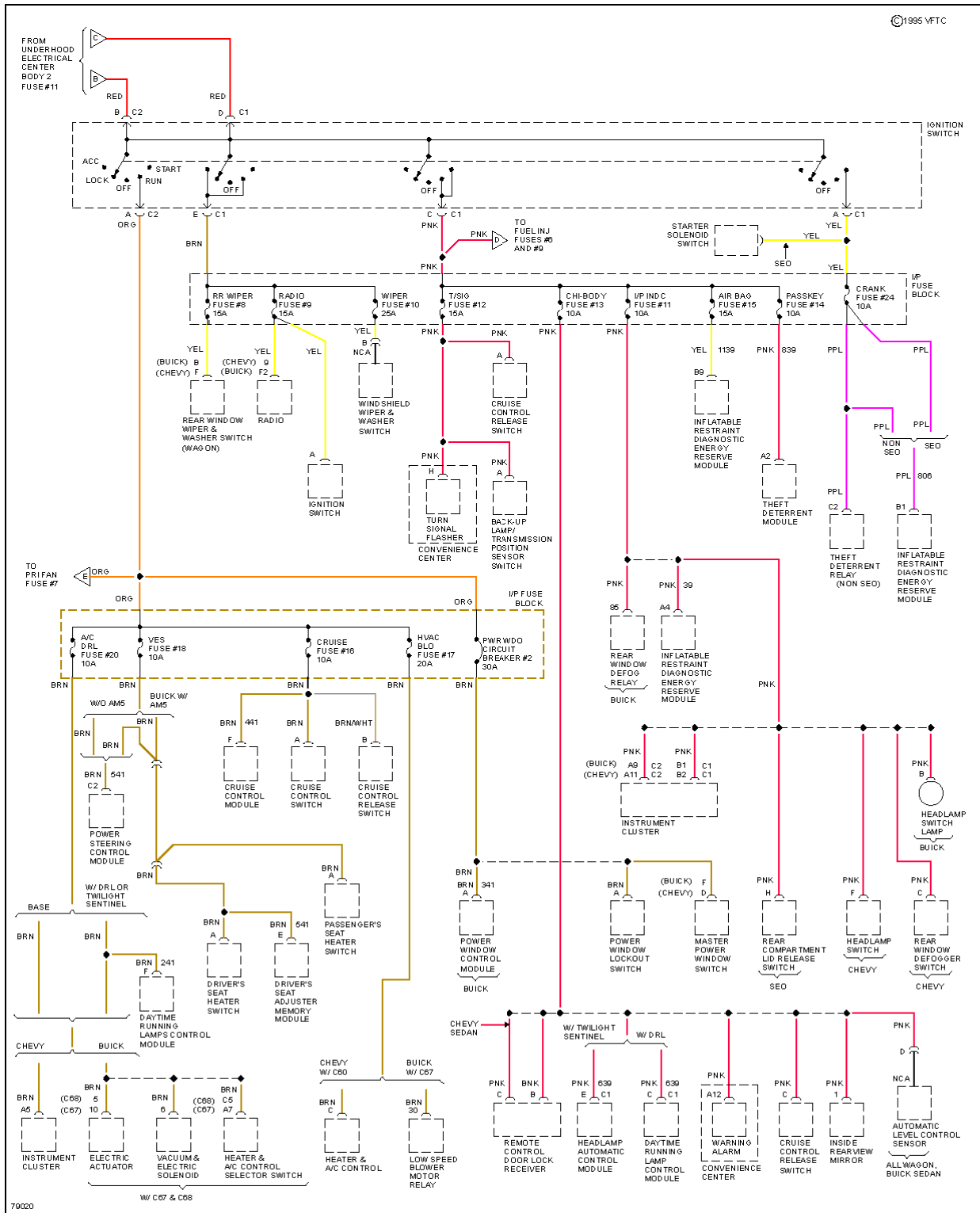
**POWER DISTRIBUTION**



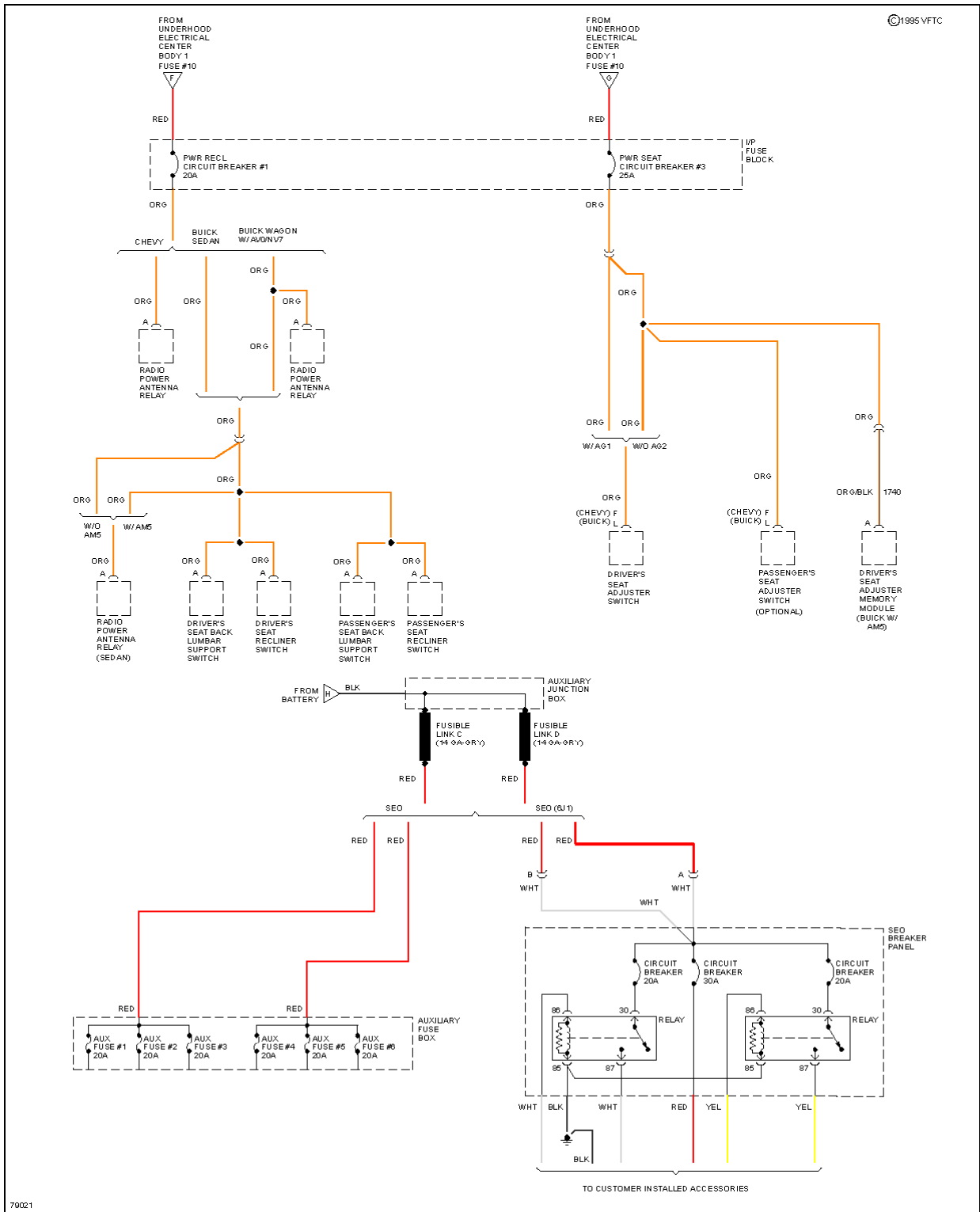
**Fig. 27: Power Distribution Circuit (1 of 4)**



**Fig. 28: Power Distribution Circuit (2 of 4)**



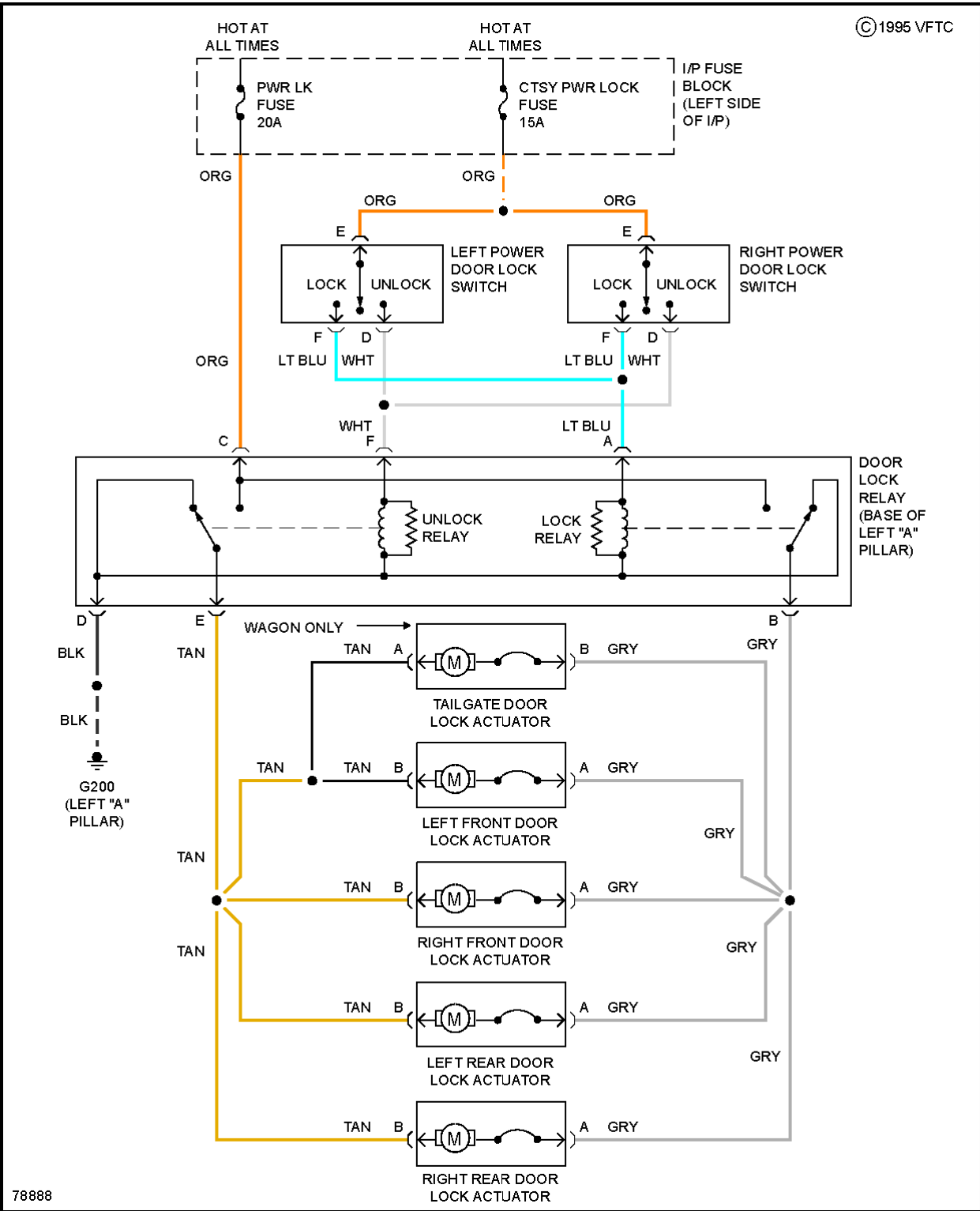
**Fig. 29: Power Distribution Circuit (3 of 4)**



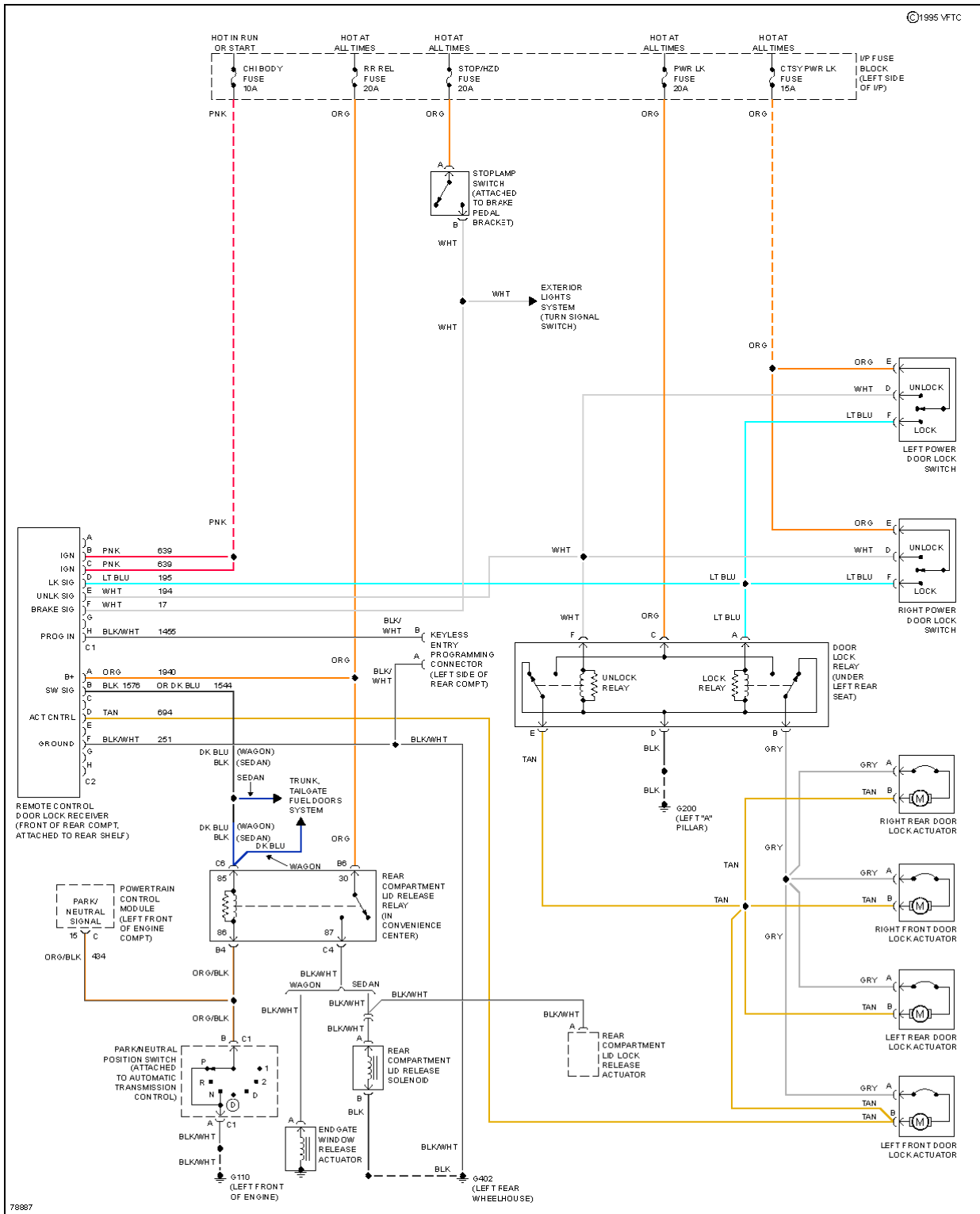
79021

**Fig. 30: Power Distribution Circuit (4 of 4)**

## POWER DOOR LOCKS



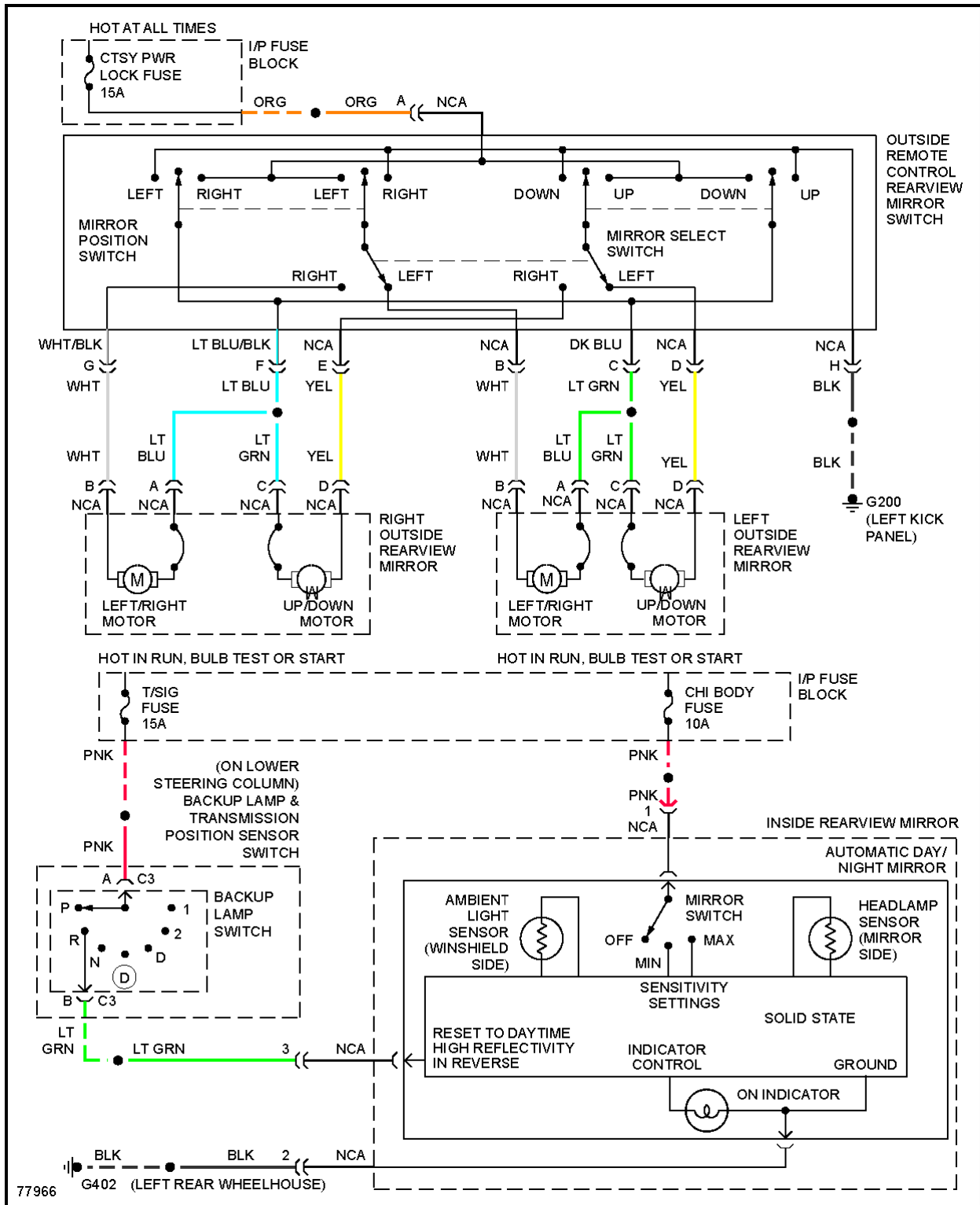
**Fig. 31: Door Lock Circuit**



**Fig. 32: Keyless Entry Circuit**

## POWER MIRRORS





**Fig. 33: Power Mirror Circuit**

## POWER SEATS

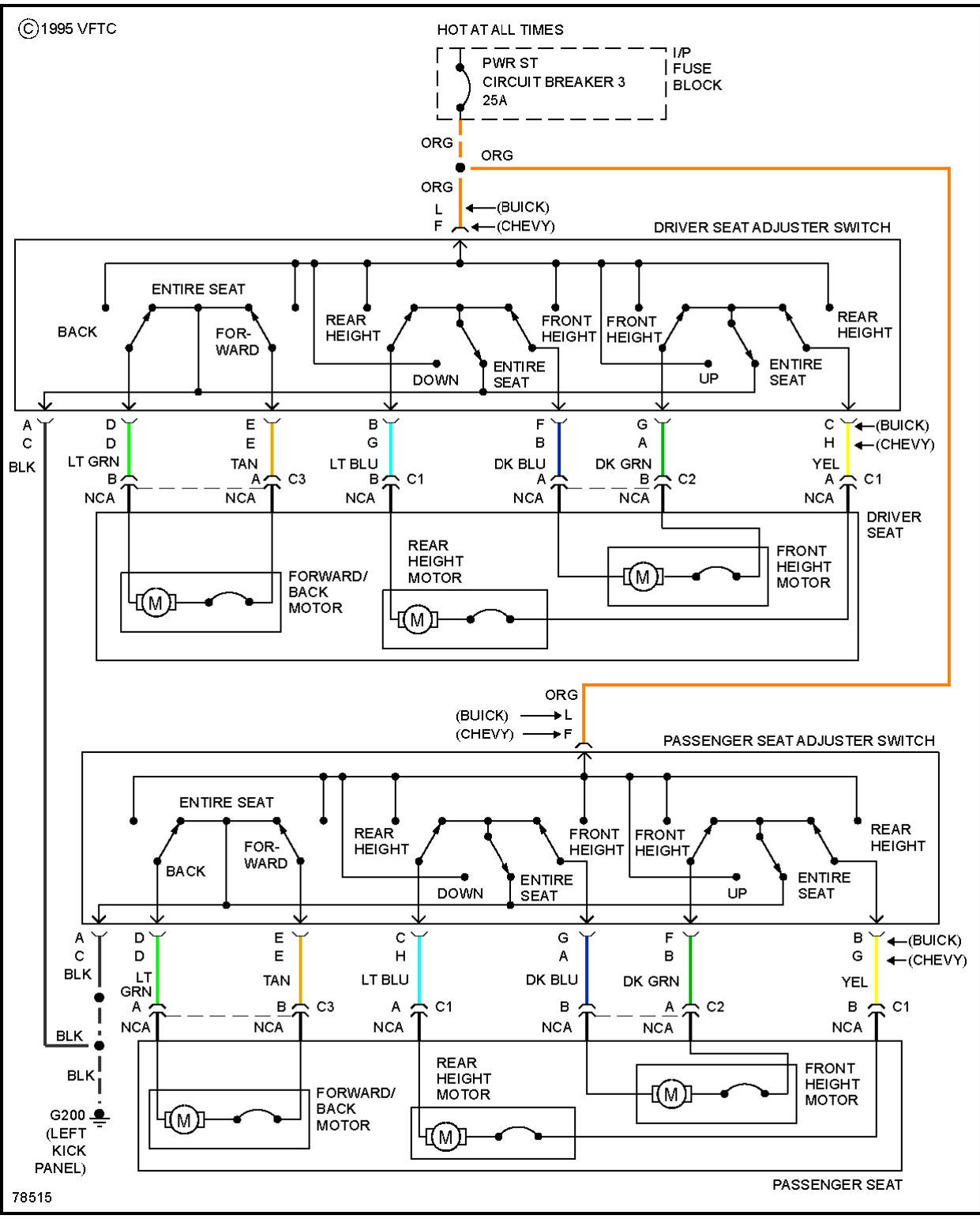
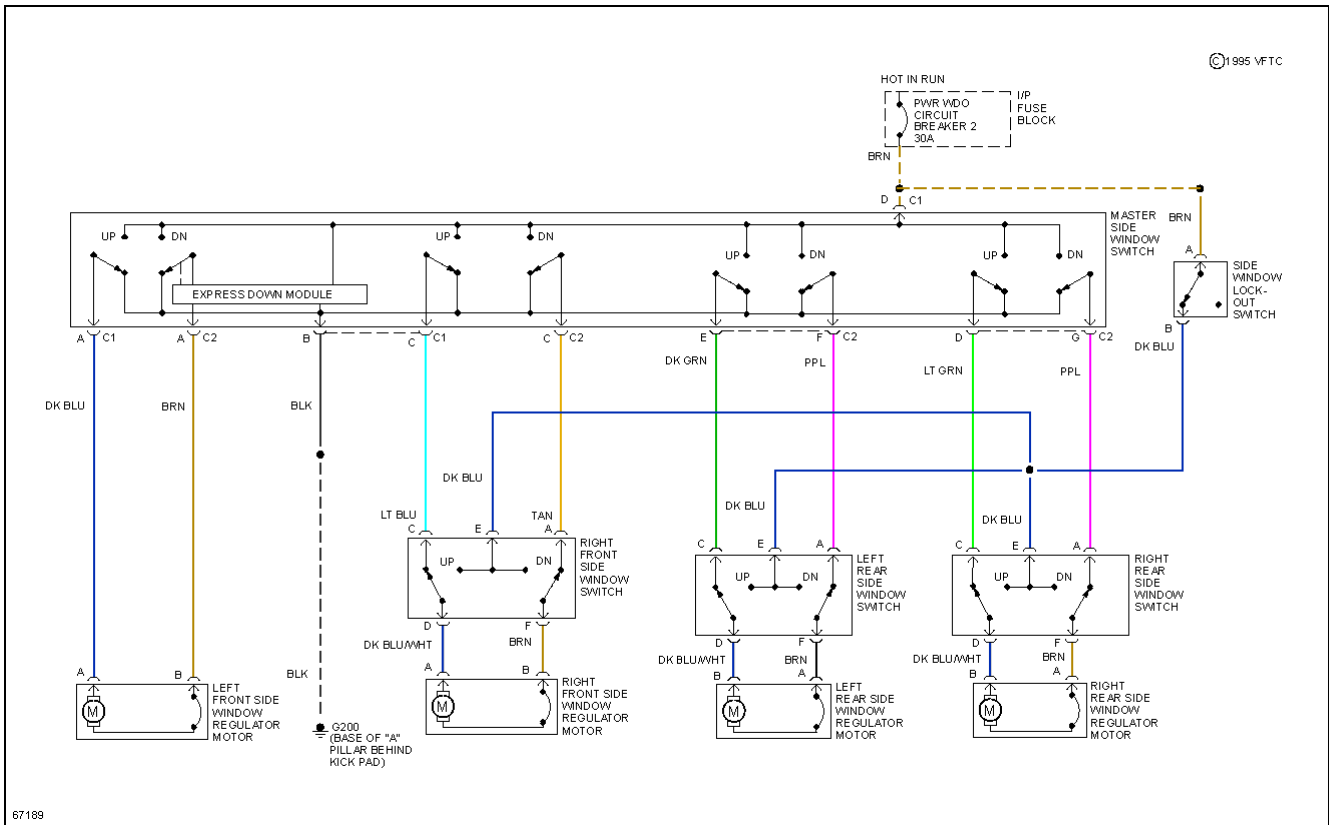


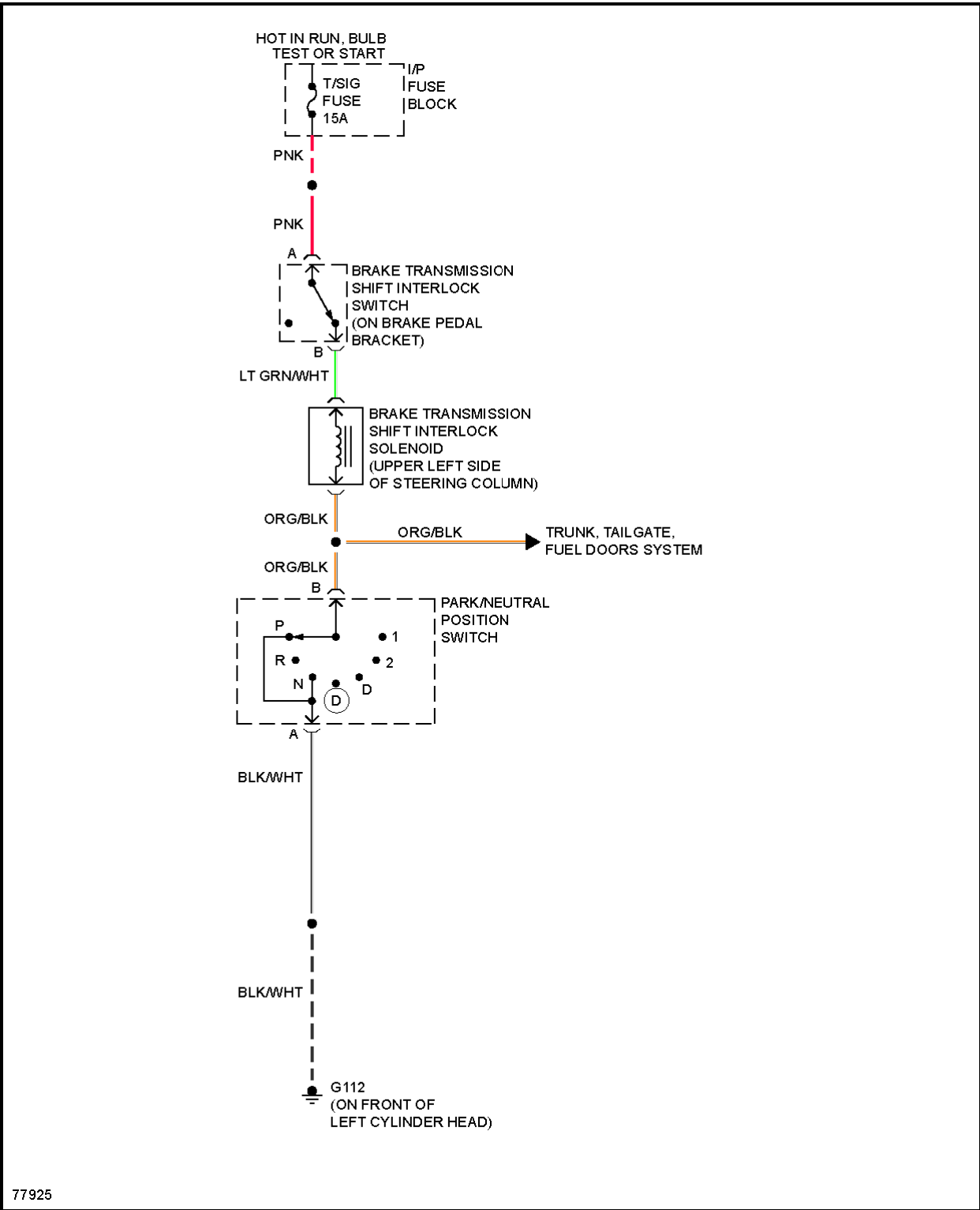
Fig. 34: 6-Way Power Seat Circuit

POWER WINDOWS



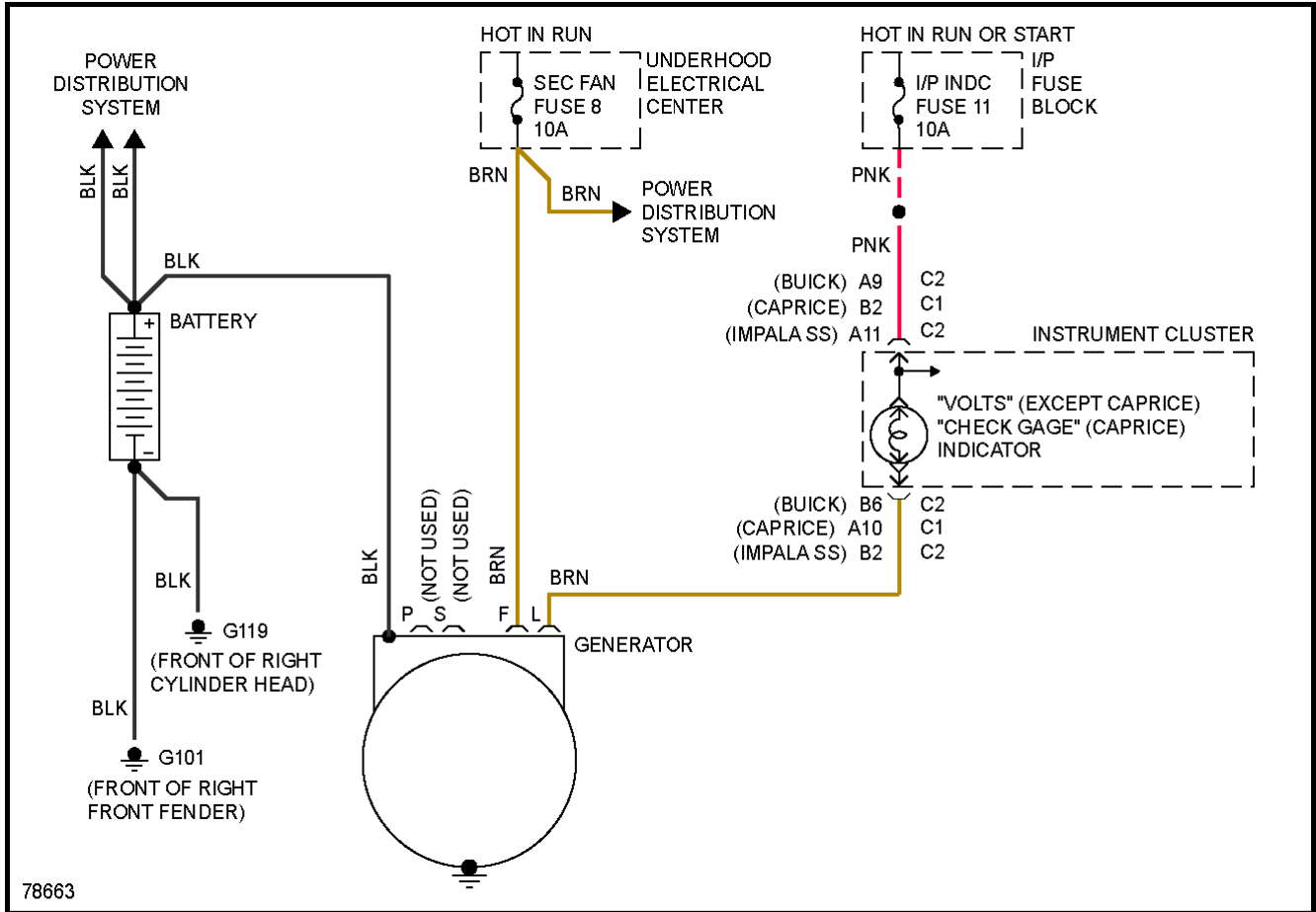
**Fig. 35: Power Window Circuit**

## SHIFT INTERLOCKS

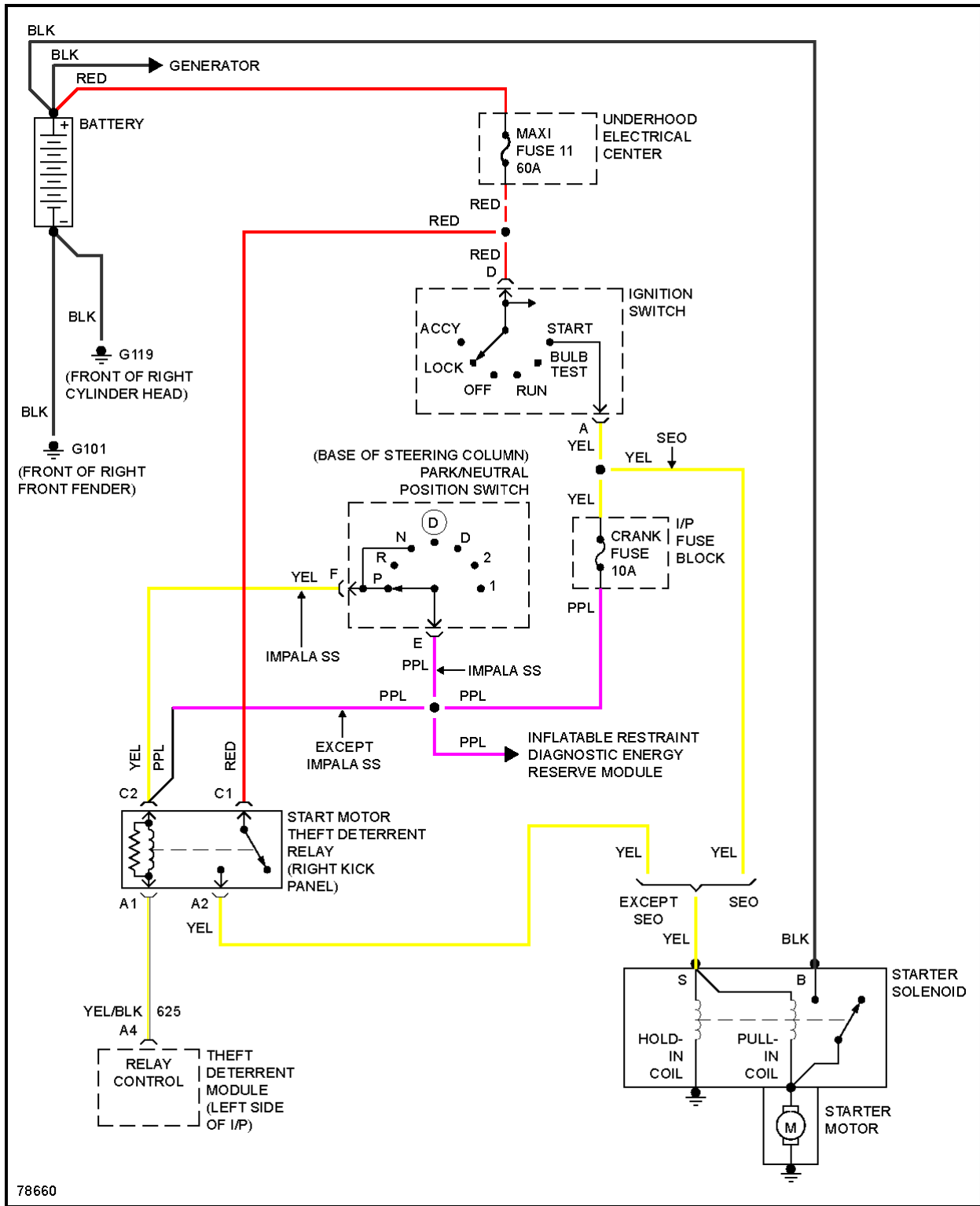


**Fig. 36: Shift Interlock Circuit**

**STARTING/CHARGING**

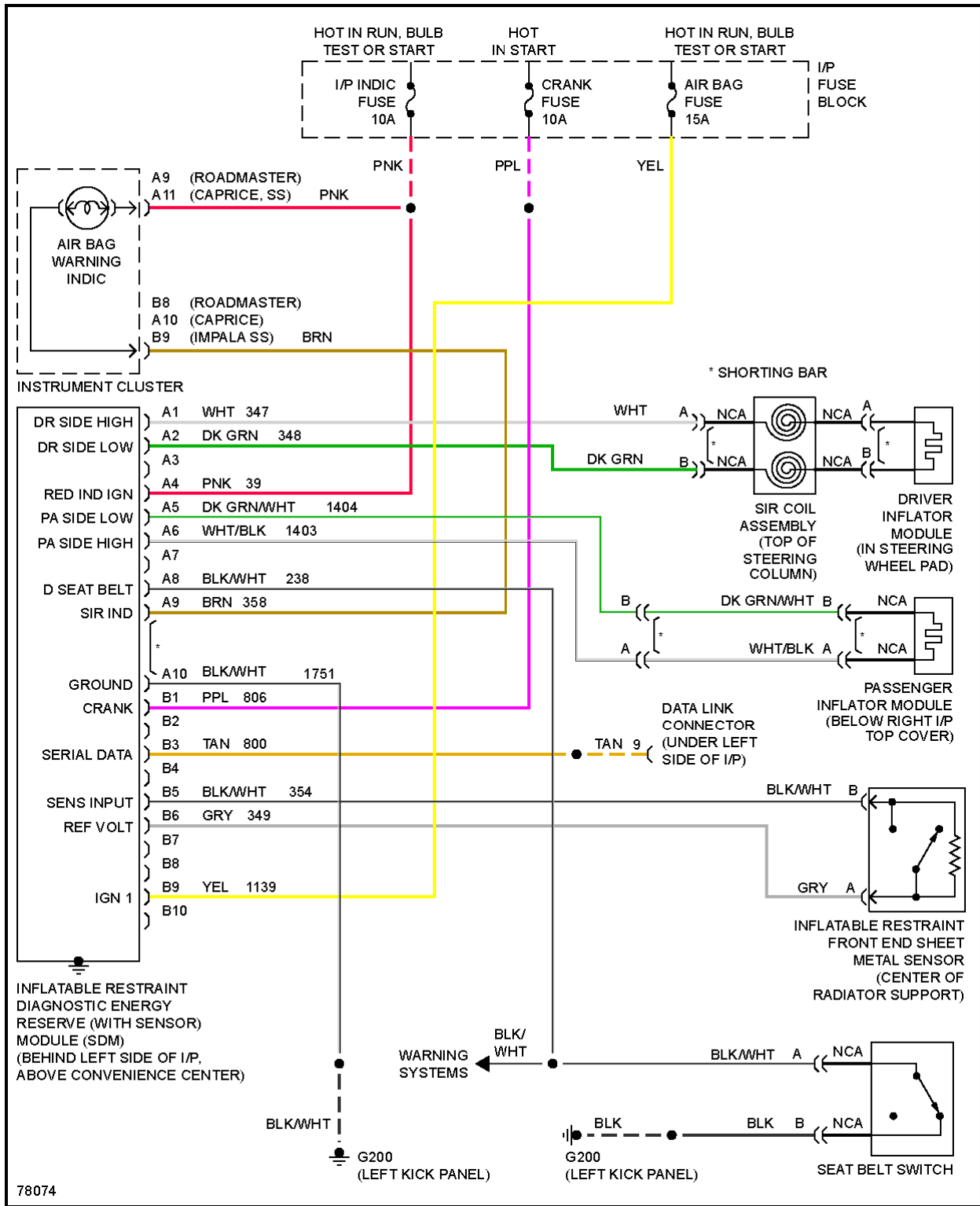


**Fig. 37: Charging Circuit**



**Fig. 38: Starting Circuit**

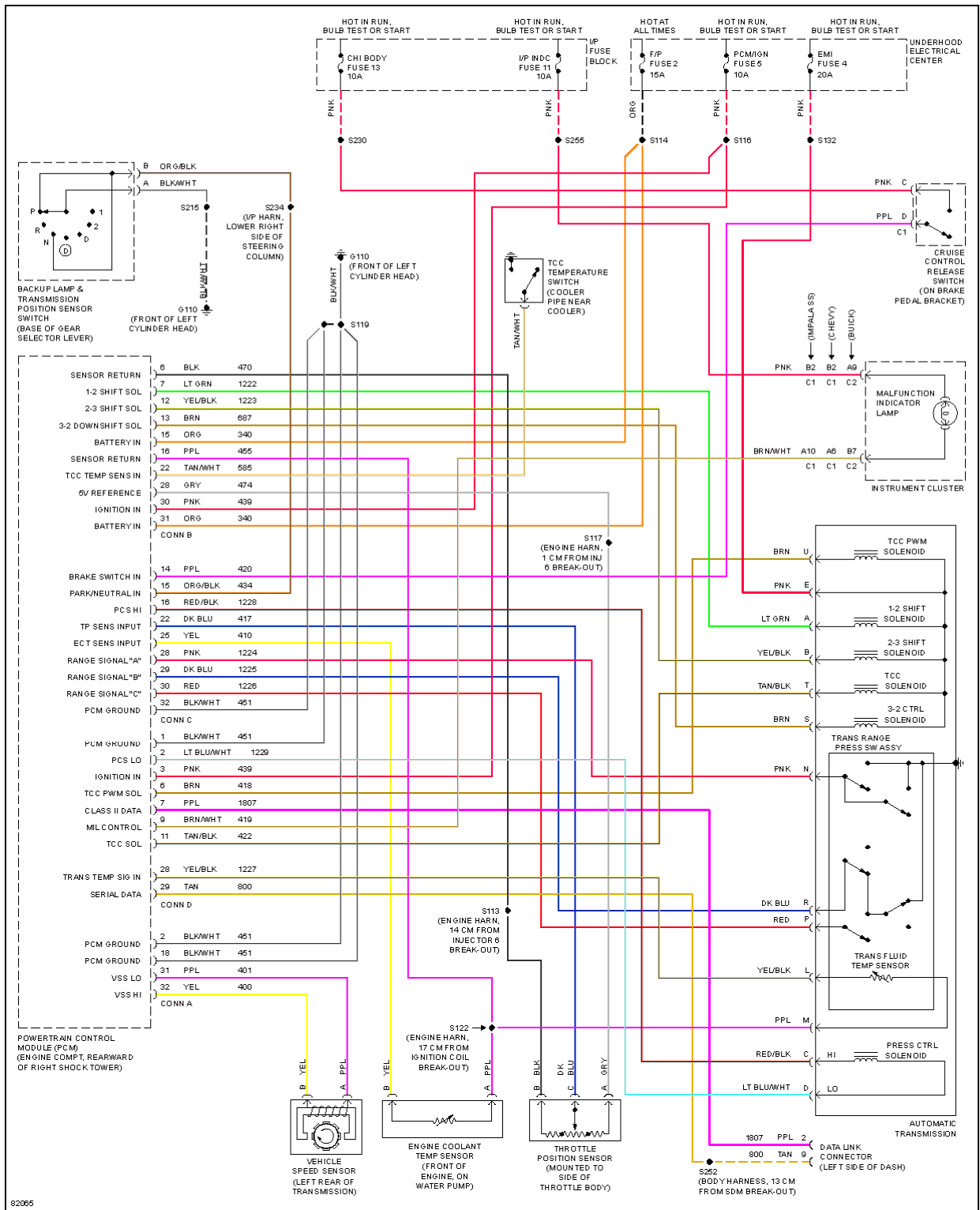
**SUPPLEMENTAL RESTRAINTS**



**Fig. 39: Supplemental Restraint Circuit**

## TRANSMISSION

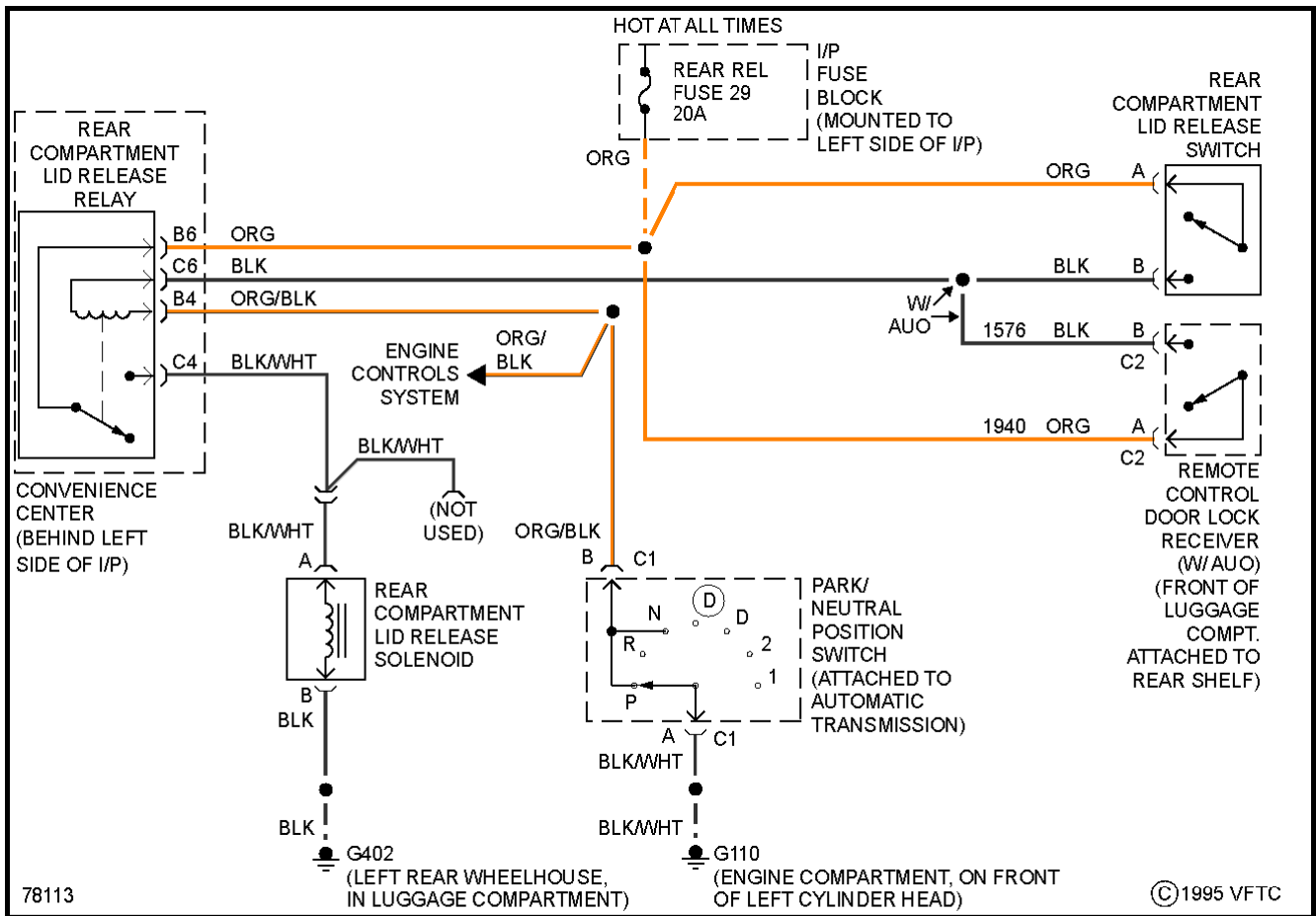
# 5.7L



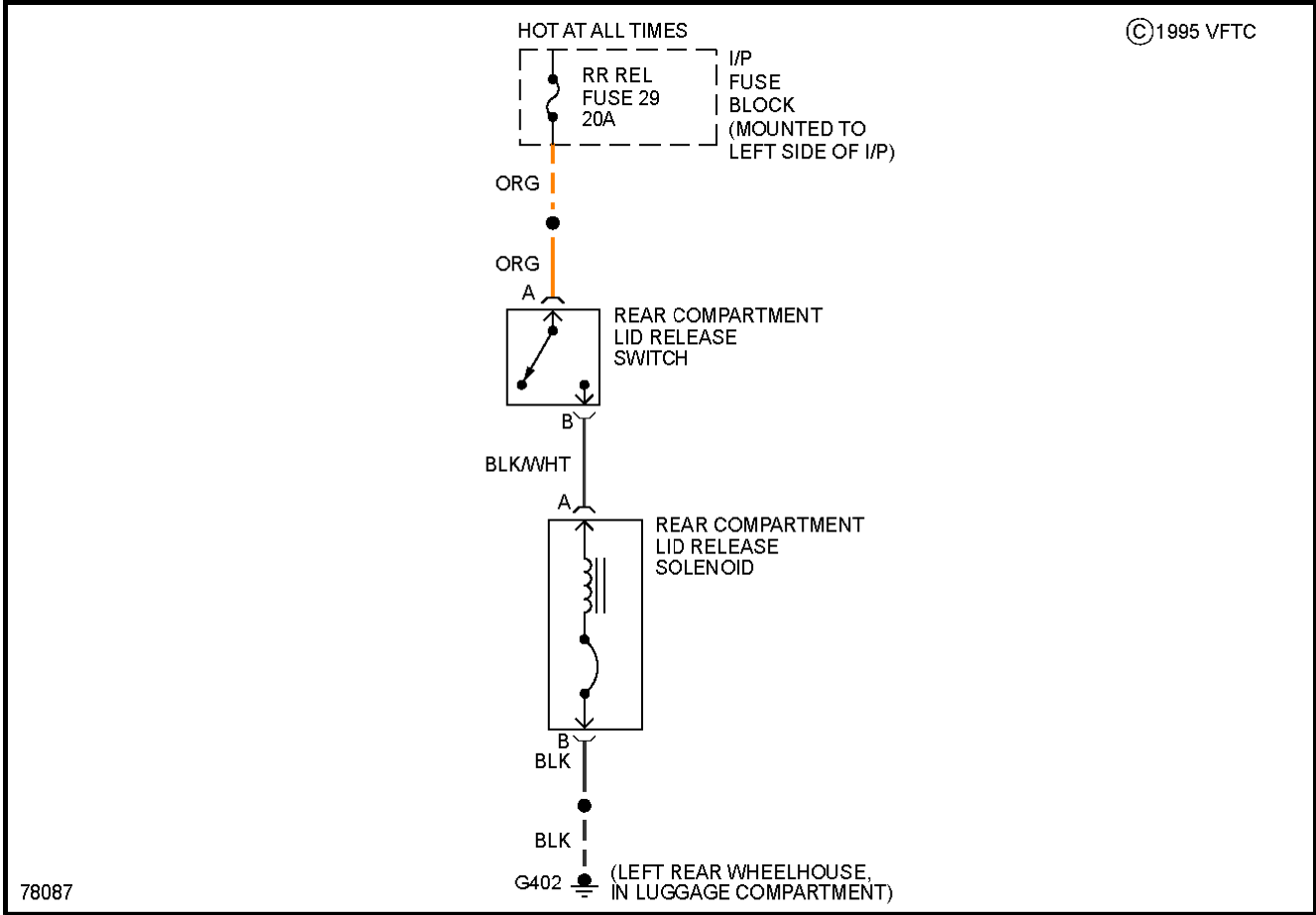
**Fig. 40: 5.7L (VIN P), Transmission Circuit**



# TRUNK, TAILGATE, FUEL DOOR



**Fig. 41: Trunk Release Circuit, W/ Keyless Entry & SEO**



**Fig. 42: Trunk Release Circuit, W/O Keyless Entry & SEO**

**WARNING SYSTEMS**

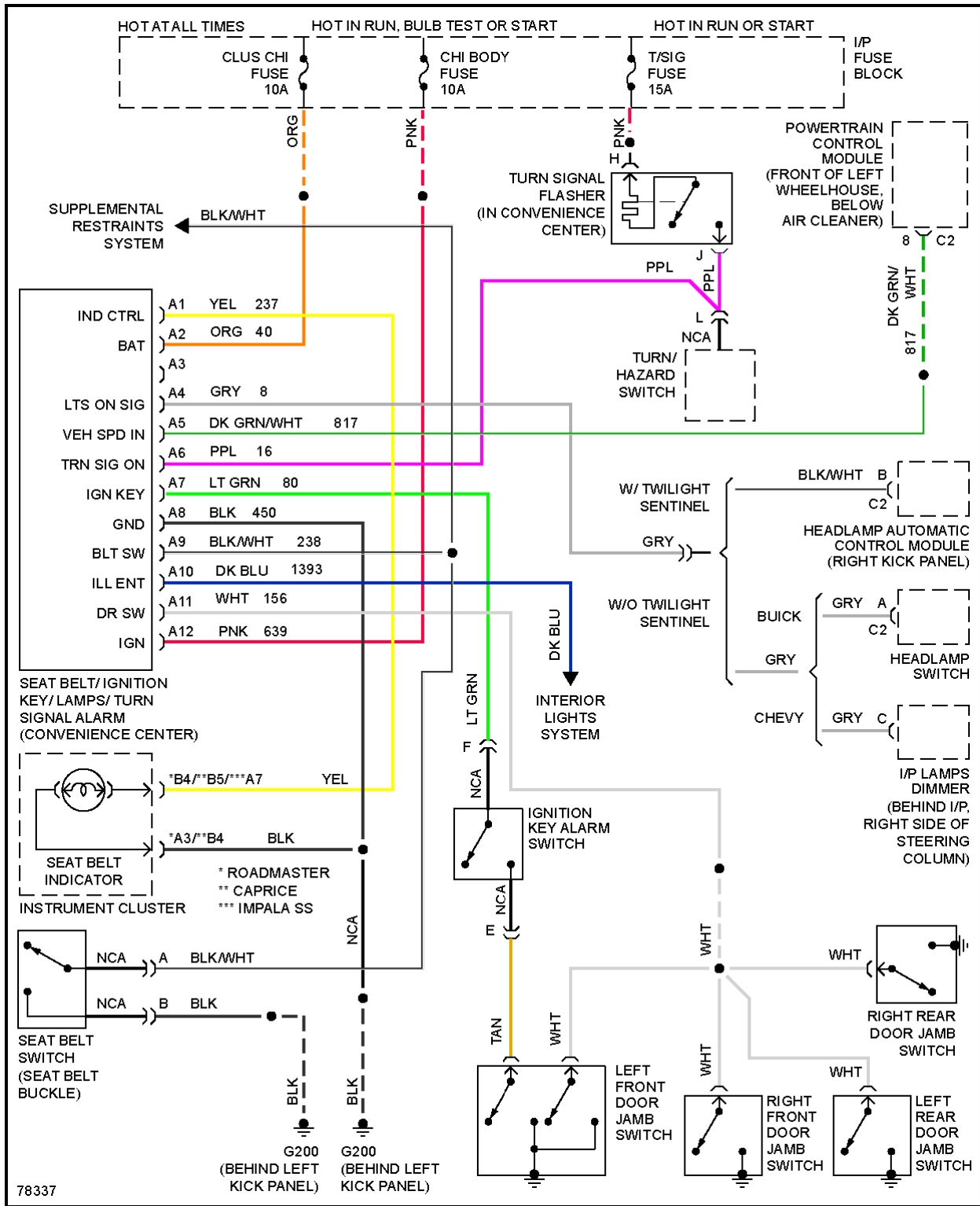
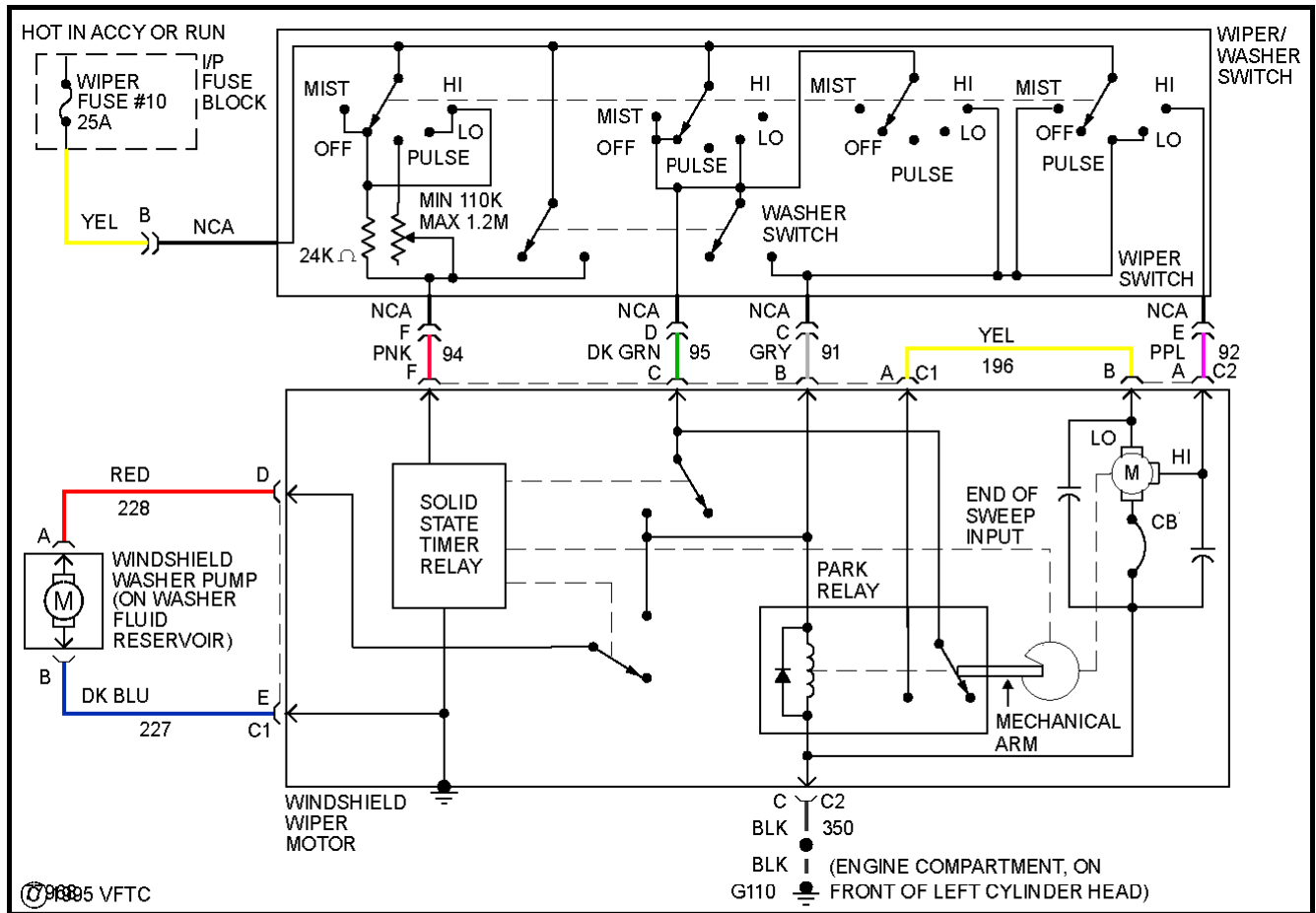


Fig. 43: Warning System Circuits

## WIPER/WASHER



**Fig. 44: Wiper/Washer Circuit**